



Singapore General Aviation Requirements - Aeroplane

Publication of the
Civil Aviation Authority of Singapore
Singapore Changi Airport
P.O.Box 1, Singapore 918141

*Copies of this document may be obtained from
the CAAS website at www.caas.gov.sg*

RECORD OF REVISIONS

EFFECTIVE DATE : 18 NOVEMBER 2010

REVISION No : 1 (ISSUE 1)

RECORD OF REVISIONS					
REV NO.	DATE	INSERTED BY	REV NO.	DATE	INSERTED BY
Issue 1	15 July 2010	CAAS			
Rev 1	18 Nov 2010	CAAS			

Intentionally Left Blank

LIST OF EFFECTIVE PAGES

EFFECTIVE DATE : 18 NOVEMBER 2010

REVISION No : 1 (ISSUE 1)

Page No.	Revision No.	Date
ROR-1	1	18 Nov 2010
ROR-2	1	18 Nov 2010
LEP-1	1	18 Nov 2010
LEP-2	1	18 Nov 2010
TOC-1	1	18 Nov 2010
TOC-2	1	18 Nov 2010
TOC-3	1	18 Nov 2010
TOC-4	1	18 Nov 2010
INTRO- 1	0	15 July 2010
INTRO- 2	0	15 July 2010
1-1	1	18 Nov 2010
1-2	1	18 Nov 2010
1-3	1	18 Nov 2010
1-4	1	18 Nov 2010
1-5	1	18 Nov 2010
1-6	1	18 Nov 2010
1-7	1	18 Nov 2010
1-8	1	18 Nov 2010
1-9	1	18 Nov 2010
1-10	1	18 Nov 2010
1-11	1	18 Nov 2010
1-12	1	18 Nov 2010
2-1	1	18 Nov 2010
2-2	1	18 Nov 2010
2-3	1	18 Nov 2010
2-4	1	18 Nov 2010
2-5	1	18 Nov 2010
2-6	1	18 Nov 2010
2-7	1	18 Nov 2010
2-8	1	18 Nov 2010
2-9	1	18 Nov 2010
2-10	1	18 Nov 2010
2-11	1	18 Nov 2010
2-12	1	18 Nov 2010
2-13	1	18 Nov 2010

Page No.	Revision No.	Date
2-14	1	18 Nov 2010
2-15	1	18 Nov 2010
2-16	1	18 Nov 2010
2-17	1	18 Nov 2010
2-18	1	18 Nov 2010
2-19	1	18 Nov 2010
2-20	1	18 Nov 2010
2-21	1	18 Nov 2010
2-22	1	18 Nov 2010
2-23	1	18 Nov 2010
2-24	1	18 Nov 2010
2-25	1	18 Nov 2010
2-26	1	18 Nov 2010
3-1	1	18 Nov 2010
3-2	1	18 Nov 2010
3-3	1	18 Nov 2010
3-4	1	18 Nov 2010
3-5	1	18 Nov 2010
3-6	1	18 Nov 2010
3-7	1	18 Nov 2010
3-8	1	18 Nov 2010
3-9	1	18 Nov 2010
3-10	1	18 Nov 2010
3-11	1	18 Nov 2010
3-12	1	18 Nov 2010
3-13	1	18 Nov 2010
3-14	1	18 Nov 2010
3-15	1	18 Nov 2010
3-16	1	18 Nov 2010
3-17	1	18 Nov 2010
3-18	1	18 Nov 2010
3-19	1	18 Nov 2010
3-20	1	18 Nov 2010
3-21	1	18 Nov 2010
3-22	1	18 Nov 2010
3-23	1	18 Nov 2010
3-24	1	18 Nov 2010
3-25	1	18 Nov 2010
3-26	1	18 Nov 2010

Page No.	Revision No.	Date
A-1	0	15 July 2010
A-2	0	15 July 2010
A-3	0	15 July 2010
A-4	0	15 July 2010
A-5	0	15 July 2010
A-6	0	15 July 2010
B-1	0	15 July 2010
B-2	0	15 July 2010
C-1	0	15 July 2010
C-2	0	15 July 2010
D-1	1	18 Nov 2010
D-2	1	18 Nov 2010
E-1	0	15 July 2010
E-2	0	15 July 2010
F-1	0	15 July 2010
F-2	0	15 July 2010
G-1	1	18 Nov 2010
G-2	1	18 Nov 2010
G-3	1	18 Nov 2010
G-4	1	18 Nov 2010
G-5	1	18 Nov 2010
G-6	1	18 Nov 2010
G-7	1	18 Nov 2010
G-8	1	18 Nov 2010
H-1	0	15 July 2010
H-2	0	15 July 2010

TABLE OF CONTENTS

EFFECTIVE DATE : 15 JULY 2010

REVISION NO : 0 (ISSUE 1)

Table of Contents

Record of Revision

List of Effective Pages

Table of Contents

Introduction

Chapter 1

1 Definitions

2 Applicability

Chapter 2 – General Aviation Operations

1 General

1.1 Compliance with laws, regulations and procedures

1.2 *Dangerous goods*

1.3 Prohibition of use of *psychoactive substances*

1.4 Reporting of *accidents*, incidents and occurrences

2 Flight Operations

2.1 Operating facilities

2.2 Operational management

2.3 Flight preparation

2.4 In-flight procedures

2.5 Duties of *pilot-in-command*

2.6 Cabin baggage (take-off and landing)

3 *Aeroplane* Performance Operating Limitations

3.1 General

4 *Aeroplane* Instruments, Equipment and Flight Documents

4.1 General

4.2 *Aeroplanes* on all flight

4.3 *Aeroplanes* operated as VFR flights

4.4 *Aeroplanes* on flights over water

- 4.5 *Aeroplanes* on flights over designated land areas
- 4.6 *Aeroplanes* on high altitude flights
- 4.7 *Aeroplanes* operated in accordance with the instrument flight rules
- 4.8 *Aeroplanes* when operated at *night*
- 4.9 *Aeroplanes* complying with Part VI of Air Navigation Order
- 4.10 Mach number indicator
- 4.11 *Aeroplanes* required to be equipped with ground proximity warning systems (GPWS)
- 4.12 Emergency locator transmitter (ELT)
- 4.13 *Aeroplanes* required to be equipped with a pressure-altitude reporting transponder
- 4.14 Microphones
- 4.15 *Aeroplanes* equipped with *head-up display (HUD)* and/or *enhanced vision systems (EVS)*

- 5 *Aeroplane Communication and Navigation Equipments***
 - 5.1 Communication equipment
 - 5.2 Navigation equipment

- 6 *Aeroplane Maintenance***
 - 6.1 Owner's *maintenance* responsibilities
 - 6.2 *Maintenance* records
 - 6.3 Modifications and *repairs*
 - 6.4 *Maintenance release*

- 7 *Aeroplane Flight Crew***
 - 7.1 Composition of the flight crew
 - 7.2 Qualifications

- 8 *Manuals, Logs and Records***
 - 8.1 *Flight manual*
 - 8.2 Journey log/ Technical log book
 - 8.3 Records of emergency and survival equipment carried

- 9 *Security***
 - 9.1 Security of *aircraft*
 - 9.2 Reporting acts of unlawful interference

Chapter 3 – Large and Turbo-jet Aeroplane

- 1 Reserved**

- 2 Reserved**

- 3 General**
 - 3.1 Compliance with laws, regulations and procedures
 - 3.2 Safety management system

- 4 Flight Operations**
 - 4.1 Operating facilities
 - 4.2 Operational management
 - 4.3 Flight preparation
 - 4.4 In-flight procedures
 - 4.5 Duties of *pilot-in-command*
 - 4.6 Cabin baggage (take-off and landing)

- 5 Aeroplane Performance Operating Limitations**
 - 5.1 General

- 6 Aeroplane Instruments, Equipment and Flight Documents**
 - 6.1 General
 - 6.2 *Aeroplanes* on all flights
 - 6.3 *Aeroplanes* in icing conditions
 - 6.4 *Aeroplanes* operated in accordance with the instrument flight rules
 - 6.5 Pressurised *aeroplanes* when carrying passengers – weather-detecting equipment
 - 6.6 *Aeroplanes* operated above 15000m (49000ft) – radiation indicator
 - 6.7 *Aeroplanes* required to be equipped with ground proximity warning systems (GPWS)
 - 6.8 *Aeroplanes* carrying passengers – cabin crew seats
 - 6.9 *Aeroplanes* required to be equipped with an airborne collision avoidance system (ACAS)
 - 6.10 *Aeroplanes* required to be equipped with a pressure-altitude reporting transponder
 - 6.11 Microphones

- 7 Aeroplane Communication and Navigation Equipments**
 - 7.1 Communication equipment
 - 7.2 Installation
 - 7.3 Electronic navigation data management

- 8 Aeroplane Maintenance**
 - 8.1 *Operator's maintenance* responsibilities
 - 8.2 *Operator's maintenance* control manual
 - 8.3 *Maintenance programme*
 - 8.4 Continuing airworthiness information – Reporting of defects to the *aircraft* type certificate holder
 - 8.5 *Maintenance release*

- 9 Aeroplane Flight Crew**
 - 9.1 Composition of the flight crew
 - 9.2 *Flight crew member* emergency duties
 - 9.3 *Flight crew member* training programmes
 - 9.4 Qualifications

10 Flight Operations Officer/Flight Despatcher

11 Manuals, Logs and Records

11.1 *Operator's maintenance control manual*

11.2 *Maintenance programme*

11.3 *Flight recorder records*

12 Cabin Crew

12.1 Assignment of emergency duties

12.2 Cabin crew at emergency evacuation stations

12.3 Protection of cabin crew during flight

12.4 Training

13 Security

13.1 Security programme

Appendix

Appendix A – Lights to be displayed by aeroplanes [From Chapter 2, Para 4.8.1]

Appendix B – Altimetry System Performance Requirements for Operation in RSVM Airspace [From Chapter 2, Para 5.2.4 (c) and 5.2.5(a)]

Appendix C – Carriage and Use of Oxygen [From Chapter 2, Para 2.3.8.1]

Appendix D – Company Operations Manual [From Chapter 3, Para 4.2.2.1]

Appendix E – Minimum Equipment List (MEL) [From Chapter 3, Para 6.1.1]

Appendix F – Noise Abatement Procedures [From Chapter 3, Para 4.4.3.1]

Appendix G – Flight Operations Officer/Flight Despatcher (FOO/FD) [From Chapter 3, Para 10.1]

Appendix H – Aviation Security Training Syllabus – All Crew [From Chapter 3, Para 13.1.3]

INTRODUCTION

EFFECTIVE DATE : 15 JULY 2010

REVISION NO : 0 (ISSUE 1)

- 1 The Singapore General Aviation Requirements (SGAR) - *Aeroplanes* is issued by the *Chief Executive* pursuant to paragraph 50A(2) of the Air Navigation Order and contains the requirements for General Aviation operations. The owner, *operator* and *pilot-in-command* of a Singapore *aeroplane* involved in any General Aviation operation shall comply with the requirements of SGAR - *Aeroplanes* and all other applicable requirements issued by the *Chief Executive*.

- 2 This SGAR- *Aeroplanes* contains the following:
 - a) Chapter 1, Paragraph 1 – Glossary of definitions used in the SGAR. (All terms that are defined in this Chapter appear in italics in the text).

 - b) Chapter 1, Paragraph 2 – Applicability and responsibility for compliance with SGAR Chapters 2 and 3.

 - c) Chapter 2 – Requirements for General Aviation operations.

 - d) Chapter 3 – Additional requirements for General Aviation operations involving large/ complex *aeroplanes* as well as corporate aviation operations.

Intentionally Left Blank

CHAPTER 1

EFFECTIVE DATE : 18 NOVEMBER 2010

REVISION NO : 1 (ISSUE 1)

1 Definitions

1.1 For the purposes of this SGAR, the following definitions shall apply :

'Accident' means an occurrence associated with the operation of an *aircraft* which takes place between the time any person boards the *aircraft* with the intention of flight until such time as all such persons have disembarked, in which:

- a) a person is fatally or seriously injured as a result of:
 - being in the *aircraft*, or
 - direct contact with any part of the *aircraft*, including parts which have become detached from the *aircraft*, or
 - direct exposure to jet blast,

except when the injuries are from natural causes, self inflicted or inflicted by other persons, or when the injuries are to stowaways hiding outside the areas normally available to the passengers and crew; or

- b) the *aircraft* sustains damage or structural failure which:
 - adversely affects the structural strength, performance or flight characteristics of the *aircraft*, and
 - would normally require major *repair* or replacement of the affected component, except for engine failure or damage, when the damage is limited to the engine, its cowlings or accessories; or for damage limited to propellers, wing tips, antennas, tires, brakes, fairings, small dents or puncture holes in the *aircraft* skin; or
- c) the *aircraft* is missing or is completely inaccessible.

'Acts of unlawful interference' means acts or attempted acts such as to jeopardise the safety of civil aviation and air transport, i.e.

- a) unlawful seizure of *aircraft* in flight,
- b) unlawful seizure of *aircraft* on the ground,
- c) hostage-taking on board an *aircraft* or on *aerodromes*,
- d) forcible intrusion on board an *aircraft*, at an airport or on the premises of an aeronautical facility,
- e) introduction on board an *aircraft* or at an airport of a weapon or hazardous device or material intended for criminal purposes,

- f) communication of false information as to jeopardise the safety of an *aircraft* in flight or on the ground, of passengers, crew, ground personnel or the general public, at an airport or on the premises of a civil aviation facility.

‘**Aerial work**’ means an *aircraft* operation in which an *aircraft* is used for specialised services such as agriculture, construction, photography, surveying, observation and patrol, search and rescue, aerial advertisement, etc.

‘**Aerodrome**’ means a defined area on land or water (including any building, installation and equipment) intended to be used either wholly or in part for the arrival, departure and surface movement of *aircraft*.

‘**Aerodrome operating minima**’ means the limits of usability of an *aerodrome* for:

- a) Take-off, expressed in terms of runway visual range and/or visibility and, if necessary, cloud conditions;
- b) landing in precision approach and landing operations, expressed in terms of visibility and/or runway visual range and *decision altitude/height* (DA/H) as appropriate to the category of the operation;
- c) landing in approach and landing operations with vertical guidance, expressed in terms of visibility and/or runway visual range and *decision altitude/height* (DA/H); and
- d) landing in non-precision approach and landing operations, expressed in terms of visibility and/or runway visual range, *minimum descent altitude/height* (MDA/H) and, if necessary, cloud conditions.

‘**Aeroplane**’ means a power-driven heavier-than-air *aircraft*, deriving its lift in flight chiefly from aerodynamic reactions on surfaces which remain fixed under given conditions of flight.

‘**Aircraft**’ means any machine that can derive support in the atmosphere from the reactions of the air other than the reactions of the air against the earth’s surface and includes a helicopter.

‘**Alternate aerodrome**’ means an *aerodrome* to which an *aircraft* may proceed when it becomes either impossible or inadvisable to proceed to or land at the *aerodrome* of intended landing. *Alternate aerodromes* include the following:

- a) ‘*Take-off alternate*’ means an *alternate aerodrome* at which an *aircraft* can land should this become necessary shortly after take-off and it is not possible to use the *aerodrome* of departure.
- b) ‘*En-route alternate*’ means an *aerodrome* at which an *aircraft* would be able to land after experiencing an abnormal or emergency condition while en route.

- c) *'Destination alternate'* means an *alternate aerodrome* to which an *aircraft* may proceed should it become either impossible or inadvisable to land at the *aerodrome* of intended landing.

Note. - *The aerodrome from which a flight departs may also be an en-route or a destination alternate aerodrome for that flight.*

'Altimetry system error (ASE)' means the difference between the altitude indicated by the altimeter display, assuming a correct altimeter barometric setting, and the pressure altitude corresponding to the undisturbed ambient pressure.

'Approach and landing operations using instrument approach procedures' means instrument approach and landing operations and are classified as follows:

- a) *Non-precision approach and landing operations.* An instrument approach and landing which utilises lateral guidance but does not utilise vertical guidance.
- b) *Approach and landing operations with vertical guidance.* An instrument approach and landing which utilises lateral and vertical guidance but does not meet the requirements established for precision approach and landing operations.
- c) *Precision approach and landing operations.* An instrument approach and landing using precision lateral and vertical guidance with minima as determined by the category of operation.

Note. - *Lateral and vertical guidance refers to the guidance provided either by:*

- i) *a ground-based navigation aid; or*
- ii) *computer generated navigation data.*
- d) *Categories of precision approach and landing operations:*
- i) *Category I (CAT I) operation.* A precision instrument approach and landing with a decision height not lower than 60 m (200 ft) and with either a visibility not less than 800 m or a runway visual range not less than 550m.
- ii) *Category II (CAT II) operation.* A precision instrument approach and landing with a decision height lower than 60 m (200 ft), but not lower than 30 m (100 ft), and a runway visual range not less than 300 m.
- iii) *Category IIIA (CAT IIIA) operation.* A precision instrument approach and landing with:
- 1) a decision height lower than 30 m (100 ft) or no decision height; and

- 2) a runway visual range not less than 175 m.
- iv) *Category IIIB (CAT IIIB) operation.* A precision instrument approach and landing with:
 - 1) a decision height lower than 15 m (50 ft) or no decision height; and
 - 2) a runway visual range less than 175 m but not less than 50 m.
- v) *Category IIIC (CAT IIIC) operation.* A precision instrument approach and landing with no decision height and no runway visual range limitations.

Note. - Where decision height (DH) and runway visual range (RVR) fall into different categories of operation, the instrument approach and landing operation would be conducted in accordance with the requirements of the most demanding category (e.g. an operation with a DH in the range of CAT IIIA but with an RVR in the range of CAT IIIB would be considered a CAT IIIB operation or an operation with a DH in the range of CAT II but with an RVR in the range of CAT I would be considered a CAT II operation).

‘Area Navigation (RNAV)’ means a method of navigation which permits *aircraft* operation on any desired flight path within the coverage of ground- or spaced-based navigation aids or within the limits of the capability of self-contained aids, or a combination of these.

Note. - Area navigation includes performance-based navigation as well as other operations that do not meet the definition of performance-based navigation.

‘Authority’ means the Civil Aviation Authority of Singapore (CAAS) established under Section 4 of the Civil Aviation Authority of Singapore Act.

‘Cabin crew member’ means a crew member who performs, in the interest of safety of passengers, duties assigned by the *operator* or the *pilot-in-command* of the *aircraft*, but who shall not act as a *flight crew member*.

“Chief Executive” means the *Chief Executive* of the Authority appointed under section 11 of the Civil Aviation Authority of Singapore Act 2009, and includes any person authorised by him to act on his behalf and any person acting in that capacity.

‘Continuing airworthiness’ means the set of processes by which all *aircraft* comply with the applicable airworthiness requirements and remain in a condition for safe operation throughout their operating life.

‘Corporate aviation operation’ means the non-commercial operation or use of *aircraft* by a company for the carriage of passengers or goods as an aid to the conduct of company business, flown by a professional pilot(s) employed to fly the *aircraft*.

‘Dangerous goods’ means any article or substance which is capable of posing a risk to health, safety, property or the environment and which is identified in the list of dangerous goods in the Technical Instructions or is classified

according to the Technical Instructions for the Safe Transport of Dangerous Goods by Air approved and published by decision of the Council of the International Civil Aviation Organisation for the time being in force.

‘Decision altitude (DA) or decision height (DH) means a specified altitude or height in the precision approach or approach with vertical guidance at which a missed approach must be initiated if the required visual reference to continue the approach has not been established.

Note.1 - Decision altitude (DA) is referenced to mean sea level and decision height (DH) is referenced to the threshold elevation.

Note.2 - The required visual reference means that section of the visual aids or of the approach area which should have been in view for sufficient time for the pilot to have made an assessment of the aircraft position and rate of change of position, in relation to the desired flight path. In Category III operations with a decision height the required visual reference is that specified for the particular procedure and operation.

Note.3 - For convenience where both expressions are used they may be written in the form “decision altitude/height” and abbreviated “DA/H”.

‘Emergency locator transmitter (ELT)’ means a generic term describing equipment which broadcast distinctive signals on designated frequencies and depending on application, may be automatically activated by impact or be manually activated . An ELT may be any of the following:

- a) *Automatic fixed ELT (ELT(AF)).*An automatically activated ELT which is permanently attached to an *aircraft*.
- b) *Automatic portable ELT(ELT(AP)).*An automatically activated ELT which is rigidly attached to an *aircraft* but readily removable from an *aircraft*.
- c) *Automatic deployable ELT (ELT(AD)).*An ELT which is rigidly attached to an *aircraft* and which is automatically deployed and activated by impact, and, in some cases, also by hydrostatic sensors. Manual deployment is also provided.
- d) *Survival ELT (ELT(S)).* An ELT which is removable from an *aircraft*, stowed so as to facilitate its ready use in an emergency, and manually activated by survivors.

‘Enhanced vision system (EVS)’ means a system to display electronic real-time images of the external scene achieved through the use of image sensors.

‘Extended flight over water’ means a flight operated over water at a distance of more than 93 km (50 NM), or 30 minutes at normal cruising speed, whichever is the lesser, away from land suitable for making an emergency landing.

‘Flight crew member’ means a licensed crew member charged with duties essential to the operation of an *aircraft* during a flight duty period.

‘Flight manual’ means a manual, associated with the certificate of airworthiness, containing limitations within which the *aircraft* is to be considered airworthy, and instructions and information necessary to the *flight crew members* for the safe operation of the *aircraft*.

‘Flight plan’ means specified information provided to air traffic services units relating to an intended flight or portion of a flight of an *aircraft*.

‘Flight recorder’ means any type of recorder installed in the *aircraft* for the purpose of complementing *accident/incident* investigation.

‘Flight simulation training device’ means an apparatus in which flight conditions are simulated on the ground and includes any one of the following:

- a) *A flight simulator*, which provides an accurate representation of the flight deck of a particular *aircraft* type to the extent that the mechanical, electrical, electronic, etc. *aircraft* systems control functions, the normal environment of *flight crew members*, and the performance and flight characteristics of that type of *aircraft* are realistically simulated;
- b) *A flight procedures trainer*, which provides a realistic flight deck environment, and which simulates instrument responses, simple control functions of mechanical, electrical, electronic, etc. *aircraft* systems, and the performance and flight characteristics of *aircraft* of a particular class;
- c) *A basic instrument flight trainer*, which is equipped with appropriate instruments, and which simulates the flight deck environment of an *aircraft* in flight in instrument flight conditions.

‘Flight time – aeroplanes’ means the total time from the moment an *aeroplane* first moves for the purpose of taking off until the moment it finally comes to rest at the end of the flight.

Note. - Flight time as here defined is synonymous with the term “block to block” time or “chock to chock” time in general usage which is measured from the time an aeroplane first moves for the purpose of taking off until it finally stops at the end of the flight.

‘General aviation operation’ means the operation of one or more *aircraft* for any purpose, including flight training, other than for public transport or *aerial work*.

‘Head-up display (HUD)’ means a display system that presents flight information into the pilot’s forward external field of view.

‘Industry codes of practice’ means guidance material developed by an industry body, for a particular sector of the aviation industry to comply with the requirements of the International Civil Aviation Organisation’s Standards and Recommended Practices, other aviation safety requirements and the best practices deemed appropriate.

‘Instrument meteorological conditions (IMC)’ means meteorological conditions expressed in terms of visibility, distance from cloud, and ceiling, less than the minima specified for visual meteorological conditions.

‘Large aeroplane’ means an *aeroplane* of a maximum certificated take-off mass of over 5700 kg.

‘Maintenance’ means the performance of tasks required to ensure the continued airworthiness of an *aircraft*, including any one or combination of overhaul, inspection, replacement, defect rectification and the embodiment of a modification or *repair*.

‘Maintenance programme’ means a document which describes the specific scheduled *maintenance* tasks and their frequency of completion and related procedures, such as a reliability programme, necessary for the safe operation of those *aircraft* to which it applies.

‘Maintenance release’ means a document which contains a certification confirming that the *maintenance* work to which it relates has been completed in a satisfactory manner, either in accordance with the approved data and the procedures described in the maintenance organisation’s procedures manual or under an equivalent system.

‘Meteorological information’ means a meteorological report, analysis, forecast, and any other statement relating to existing or expected meteorological conditions.

‘Minimum descent altitude (MDA) or minimum descent height (MDH)’ means a specified altitude or height in a *non-precision approach* or circling approach below which descent must not be made without the required visual reference.

Note.1. - Minimum descent altitude (MDA) is referenced to mean sea level and minimum descent height (MDH) is referenced to the aerodrome elevation or to the threshold elevation if that is more than 2 m (7 ft) below the aerodrome elevation. A minimum descent height for a circling approach is referenced to the aerodrome elevation.

Note.2. - The required visual reference means that section of the visual aids or of the approach area which should have been in view for sufficient time for the pilot to have made an assessment of the aircraft position and rate of change of position, in relation to the desired flight path. In the case of a circling approach the required visual reference is the runway environment.

Note.3. - For convenience when both expressions are used they may be written in the form “minimum descent altitude/height” and abbreviated “MDA/H”.

‘Navigation specification’ means a set of *aircraft* and flight crew requirements needed to support performance-based navigation operations within a defined airspace. There are two kinds of navigation specifications:

- a) *Required navigation performance (RNP specification)*. A navigation specification based on area navigation that includes the requirement for performance monitoring and alerting, designated by the prefix RNP, e.g. RNP 4, RNP APCH.
- b) *Area navigation (RNAV specification)*. A navigation specification based on area navigation that does not include the requirement for performance monitoring and alerting, designated by the prefix RNAV, e.g. RNAV 5, RNAV 1.

‘Night’ means the time between 20 minutes after sunset and 20 minutes before sunrise, sunset and sunrise being determined at surface level.

‘Obstacle clearance altitude (OCA) or obstacle clearance height (OCH)’ means the lowest altitude or the lowest height above the elevation of the relevant runway threshold or the *aerodrome* elevation as applicable, used in establishing compliance with appropriate obstacle clearance criteria.

Note.1. - Obstacle clearance altitude is referenced to mean sea level and obstacle clearance height is referenced to the threshold elevation or in the case of non-precision approaches to the aerodrome elevation or the threshold elevation if that is more than 2 m (7 ft) below the aerodrome elevation. An obstacle clearance height for a circling approach is referenced to the aerodrome elevation.

Note.2. - For convenience when both expressions are used they may be written in the form “obstacle clearance altitude/height” and abbreviated “OCA/H”.

‘Operating base’ means the location from which operational control is exercised.

Note. - An operating base is normally the location where personnel involved in the operation of the aeroplane work and the records associated with the operation are located. An operating base has a degree of permanency beyond that of a regular point of call.

‘Operational control’ means the exercise of authority over the initiation, continuation, diversion or termination of a flight in the interest of the safety of the *aircraft* and the regularity and efficiency of the flight.

‘Operational flight plan’ means the *operator’s* plan for the safe conduct of the flight based on considerations of *aeroplane* performance, other operating limitations and relevant expected conditions on the route to be followed and at the *aerodromes* concerned.

‘Operations manual’ means a manual containing procedures, instructions and guidance for use by operational personnel in the execution of their duties.

‘Operator’ means a person, organisation or enterprise engaged in or offering to engage in an *aircraft* operation.

Note. - In the context of the requirements contained in this publication, the operator is not engaged in the transport of passengers, cargo or mail for remuneration or hire.

‘Performance-based navigation (PBN)’ means area navigation based on performance requirements for *aircraft* operating along an ATS route, on an instrument approach procedure or in a designated airspace.

Note. - Performance requirements are expressed in navigation specifications (RNAV specification, RNP specification) in terms of accuracy, integrity, continuity, availability and functionality needed for the proposed operation in the context of a particular airspace concept.

‘Pilot-in-command’ means the pilot designated by the *operator* as being in command and charged with the safe conduct of a flight.

‘Psychoactive substances’ means alcohol, opioids, cannabinoids, sedatives and hypnotics, cocaine, other psychostimulants, hallucinogens, and volatile solvents, but excludes coffee and tobacco.

‘RCP type’ means a label (e.g. RCP 240) that represents the values assigned to RCP parameters for communication transaction time, continuity, availability and integrity.

‘Repair’ means the restoration of an aeronautical product to an airworthy condition to ensure that the *aircraft* continues to comply with the design aspects of the appropriate airworthiness requirements used for the issuance of the type certificate for the respective *aircraft* type, after it has been damaged or subjected to wear.

‘Required communication performance (RCP)’ means a statement of the performance requirements for operational communication in support of specific air traffic management (ATM) functions.

‘Runway visual range (RVR)’ means the range over which the pilot of an *aircraft* on the centre line of a runway can see the runway surface markings or the lights delineating the runway or identifying its centre line.

‘Serious incident’ means an incident involving circumstances indicating that an *accident* nearly occurred.

‘State of Registry’ means the State on whose register the *aircraft* is entered.

‘Target level of safety (TLS)’ means a generic term representing the level of risk which is considered acceptable in particular circumstances.

‘Total vertical error (TVE)’ means the vertical geometric difference between the actual pressure altitude flown by an *aircraft* and its assigned pressure altitude (flight level).

‘Visual meteorological conditions ‘VMC’ means meteorological conditions expressed in terms of visibility, distances from cloud, and ceiling, equal to or better than specified minima.

2 Applicability

2.1 The Singapore General Aviation Requirements (SGAR) - *Aeroplanes* is applicable to general aviation operations using Singapore-registered *aeroplanes*.

2.2 SGAR - *Aeroplanes* sets out the requirements for *aeroplanes* operated for general aviation operations. Chapter 2 applies to all general aviation operations and Chapter 3 specifies additional requirements for corporate aviation operations, or general aviation operations using large *aeroplanes*, or turbine *aeroplanes*.

SGAR Part I, Chapter 2 Applicable to all General Aviation operations.

SGAR Part I, Chapter 3 Additional requirements applicable to General Aviation operations involving:

- a) any *aeroplane* with a maximum certificated take-off mass exceeding 5700kg; or
- b) any *aeroplane* with a seating configuration of more than 9 passenger seats, or
- c) any *aeroplane* equipped with one or more turbine engines; or
- d) any *aeroplane* which is part of a corporate aviation operation involving three or more *aircraft* that are operated by pilots employed for the purpose of flying the *aircraft*.

2.3 An owner, *operator* and *pilot-in-command* of an *aeroplane* registered in Singapore used in any general aviation operation shall comply with the relevant requirements specified in this SGAR.

2.4 Unless otherwise notified to the *Chief Executive*, the owner of an *aeroplane* will be treated as the *operator* of that *aeroplane*. If the owner is not the *operator* of the *aeroplane*, the owner shall notify and provide all required particulars of the *operator* to the *Chief Executive*. Such notification shall be done on Form AW148. The owner shall submit a new form to the *Chief Executive* 30 days prior to any changes to the appointment of an *operator*. An appointed *operator* shall be responsible to comply with all requirements charged under the responsibilities of the *operator* as specified in the SGAR.

2.5 If an *aeroplane* is leased, the lessee shall take on the responsibilities of the owner in this paragraph.

Intentionally Left Blank

CHAPTER 2

GENERAL AVIATION OPERATIONS

EFFECTIVE DATE : 18 NOVEMBER 2010
REVISION NO : 1 (ISSUE 1)

1 GENERAL

1.1 Compliance with laws, regulations and procedures

1.1.1 The *pilot-in-command* of a Singapore *aeroplane* to which this Chapter applies shall –

- a) comply with the laws, regulations and procedures of those States in which operations are conducted;
- b) be familiar with the laws, regulations and procedures, pertinent to the performance of his or her duties, prescribed for the areas to be traversed, the *aerodromes* to be used and the air navigation facilities relating thereto. The *pilot-in-command* shall ensure that other members of the flight crew are familiar with such of these laws, regulations and procedures as are pertinent to the performance of their respective duties in the operation of the *aeroplane*;
- c) have responsibility for *operational control*;
- d) notify the appropriate local authority without delay, if an emergency situation which endangers the safety or security of the *aeroplane* or persons necessitates the taking of action which involves a violation of local regulations or procedures. If required by the State in which the incident occurs, the *pilot-in-command* shall submit a report on any such violation to the appropriate authority of such State; in that event, the *pilot-in-command* shall also submit a copy of it to the *Chief Executive* during the next working day from the time of landing;
- e) have available on board the *aeroplane* the essential information concerning the search and rescue services in the area over which the *aeroplane* will be flown;
- f) ensure that *flight crew members* demonstrate the ability to speak and understand the language used for aeronautical radiotelephony communications.

1.2 Dangerous goods

1.2.1 A Singapore-registered *aeroplane* to which this chapter applies shall not carry any *dangerous goods* unless —

- a) the *Chief Executive* has granted to the *operator* a *dangerous goods* permit, subject to such conditions as he thinks fit, to carry *dangerous goods* on board its *aeroplane*; and

- b) such goods are carried or loaded as cargo in accordance with –
 - i) the provisions of the Air Navigation Order and any conditions to which such approval may be subject; and
 - ii) in accordance with the Technical Instructions for the Safe Transport of Dangerous Goods by Air approved and published by decision of the Council of the International Civil Aviation Organisation for the time being in force.

1.2.2 An application for a *dangerous goods* permit shall be submitted to the *Chief Executive* no later than 7 days before the date of shipment. An applicant for a *dangerous goods* permit shall submit the information required in the Air Navigation Order and the duly completed *dangerous goods* transport document at the time the application is made. The *Chief Executive* may issue a *dangerous goods* permit for the carriage of *dangerous goods* on a single return flight (ad hoc permit) or on more than 10 return flights over a period of 6 months (block permit).

1.2.3 Paragraphs 1.2.1 and 1.2.2 shall not apply to *dangerous goods* that are –

- a) required to be aboard the *aeroplane* in accordance with the relevant airworthiness requirements and operating regulations or that are authorised by the State of the *operator* to meet special requirements;
- b) required to provide, during flight, medical aid to a patient;
- c) required to provide, during flight, veterinary aid or a humane killer for an animal;
- d) required to provide, during flight, aid in connection with search and rescue operations;
- e) permitted for carriage by passengers or crew members;
- f) intended for use or sale during the flight in question;
- g) vehicles carried in *aeroplane* designed or modified for vehicle ferry operations; or
- h) required for the propulsion of the means of transport or the operation of its specialised equipment during transport such as refrigeration units or that are required in accordance with any operating regulations such as fire extinguishers;

and are carried in compliance with the Technical Instructions.

1.2.4 Further provisions and information on the carriage of *dangerous goods* can be found in the Air Navigation Order.

1.3 Prohibition of use of psychoactive substances

1.3.1 No member of a flight crew shall perform any function specified in the privileges applicable to his licence if he is under the influence of any psychoactive substance which may render him unable to perform such functions in a safe and proper manner.

1.3.2 No person whose function is critical to the safety of aviation (safety-sensitive personnel) shall undertake that function while under the influence of any psychoactive substance, by reason of which human performance is impaired. No such person shall engage in any kind of problematic use of substances.

1.4 Reporting of *accidents*, incidents and occurrences

1.4.1 *Operators*, pilots-in-command and maintenance organisations of Singapore-registered *aircraft* are required to report any *accidents*, incidents or occurrences which endangers, or unless corrected would have endangered the flight crew and passengers and *aircraft* (such as unlawful interference, air rage etc). The written report is to be submitted to the *Chief Executive* as follows:

- a) *Accident* – report by phone immediately to the Airworthiness and Flight Operations Division Duty Officer followed by written (fax) report within three hours of the occurrence of the *accident*.
- b) *Serious Incident* – report within one working day from time upon landing.
- c) *Incident* – report within three working days from time upon landing.

1.4.2 The *pilot-in-command* of a Singapore *aeroplane* to which this Chapter applies shall report any hazardous conditions, other than those associated with meteorological conditions, to the appropriate aeronautical station as soon as possible. The reports so rendered shall give such details as may be pertinent to the safety of other *aircraft*.

1.4.3 The *pilot-in-command* of a Singapore *aeroplane* to which this Chapter applies shall report all known or suspected defects in the *aircraft* to the *operator* at the termination of the flight in accordance with SAR Chapter 4.5.

2 FLIGHT OPERATIONS

2.1 Operating facilities

2.1.1 The *pilot-in-command* of a Singapore *aeroplane* to which this Chapter applies shall ensure that a flight will not be commenced unless it has been ascertained by every reasonable means available that the ground and/or water facilities including communication facilities and navigation aids available and directly required on such flight, for the safe operation of the *aeroplane*, are adequate for the type of operation under which the flight is to be conducted.

2.2 Operational management

2.2.1 Operating instructions – general

2.2.1.1 An *aeroplane* shall not be taxied on the movement area of an *aerodrome* unless the person at the controls is an appropriately qualified pilot or:

- a) has been duly authorised by the *operator*;
- b) is fully competent to taxi the *aeroplane*;
- c) is qualified to use the radio if radio communications are required; and
- d) has received instruction from a competent person in respect of *aerodrome* layout, and where appropriate, information on routes, signs, marking, lights, ATC signals and instructions, phraseology and procedures, and is able to conform to the operational standards required for safe *aeroplane* movement at the *aerodrome*.

2.2.2 Aerodrome operating minima

2.2.2.1 The *pilot-in-command* of a Singapore *aeroplane* to which this Chapter applies shall not operate to or from an *aerodrome* using operating minima lower than those which may be established for that *aerodrome* by the State in which it is located, except with the specific approval of the State.

Note. – Operations with lower visibilities than normally associated with the *aerodrome operating minima* may only be allowed on an *aeroplane* with HUB and/or EVS if approval has been obtained in accordance to paragraph 4.15.1.

2.2.3 Passengers

2.2.3.1 The *pilot-in-command* of a Singapore *aeroplane* to which this Chapter applies shall ensure that passengers are made familiar with the location and use of:

- a) seat belts;
- b) emergency exits;
- c) life jackets, if the carriage of life jackets is prescribed;
- d) oxygen dispensing equipment; and

- e) other emergency equipment provided for individual use,
- f) including passenger emergency briefing cards.

2.2.3.2 The *pilot-in-command* of a Singapore *aeroplane* to which this Chapter applies shall ensure that:

- a) all persons on board are aware of the location and general manner of use of the principal emergency equipment carried for collective use;
- b) passengers are instructed in such emergency action as may be appropriate to the circumstances in an emergency during flight; and
- c) during take-off and landing and whenever considered necessary by reason of turbulence or any emergency occurring during flight, all passengers on board an *aeroplane* shall be secured in their seats by means of the seat belts or harnesses provided.

2.3 Flight preparation

2.3.1 A flight shall not be commenced until the *pilot-in-command* of a Singapore *aeroplane* to which this Chapter applies is satisfied that:

- a) the *aeroplane* is airworthy, duly registered and that appropriate certificates as required under the Air Navigation Order are aboard the *aeroplane*;
- b) the instruments and equipment installed in the *aeroplane* are appropriate, taking into account the expected flight conditions;
- c) any necessary *maintenance* has been performed in accordance with Section 6 of this Chapter;
- d) the mass of the *aeroplane* and centre of gravity location are such that the flight can be conducted safely, taking into account the flight conditions expected;
- e) any load carried is properly distributed and safely secured; and
- f) the *aeroplane* operating limitations, contained in the *flight manual*, or its equivalent, will not be exceeded.

2.3.2 The *pilot-in-command* of a Singapore *aeroplane* to which this Chapter applies shall have sufficient information on climb performance with all engines operating to enable determination of the climb gradient that can be achieved during the departure phase for the existing take-off conditions and intended take-off technique.

2.3.3 Flight Planning

2.3.3.1 Before commencing a flight the *pilot-in-command* of a Singapore *aeroplane* to which this Chapter applies shall be familiar with all available

meteorological information appropriate to the intended flight. Preparation for a flight away from the vicinity of the place of departure, and for every flight under the instrument flight rules, shall include:

- a) a study of available current weather reports and forecasts; and
- b) the planning of an alternative course of action to provide for the eventuality that the flight cannot be completed as planned, because of weather conditions.

2.3.4 Weather conditions

2.3.4.1 A flight to be conducted in accordance with the visual flight rules shall not be commenced unless current meteorological reports or a combination of current reports and forecasts indicate that the meteorological conditions along the route or that part of the route to be flown under the visual flight rules will, at the appropriate time, be such as to render compliance with these rules possible.

2.3.4.2 A flight to be conducted in accordance with the instrument flight rules shall not be commenced unless information is available which indicates that conditions at the *aerodrome* of intended landing or, where a *destination alternate* is required, at least one *destination alternate aerodrome* will, at the estimated time of arrival, be at or above the *aerodrome operating minima*.

2.3.4.3 A flight to be operated in known or expected icing conditions shall not be commenced unless the *aeroplane* is certificated and equipped to cope with such conditions.

2.3.4.4 A flight to be planned or expected to operate in suspected or known ground icing conditions shall not take off unless the *aeroplane* has been inspected for icing and, if necessary, has been given appropriate de-icing/anti-icing treatment. Accumulation of ice or other naturally occurring contaminants shall be removed so that the *aeroplane* is kept in an airworthy condition prior to take-off.

2.3.5 Alternate aerodromes

2.3.5.1 A flight to be conducted in accordance with the instrument flight rules shall not be commenced without at least one *destination alternate aerodrome* selected and specified in the *flight plans*, unless:

- a) the duration of the flight and the meteorological conditions prevailing are such that there is reasonable certainty that, at the estimated time of arrival at the *aerodrome* of intended landing, and for a reasonable period before and after such time, the approach and landing may be made under visual meteorological conditions; or
- b) the *aerodrome* of intended landing is isolated and there is no suitable *destination alternate aerodrome*; and

- i) a standard instrument approach procedure is prescribed for the *aerodrome* of intended landing; and
- ii) available current *meteorological information* indicates that the following meteorological
- iii) conditions will exist from two hours before time of arrival:
 - 1) a cloud base of at least 300 m (1000 ft) above the minimum associated with the instrument approach procedure; and
 - 2) visibility of at least 5.5 km or of 4 km more than the minimum associated with the procedure.

2.3.6 Fuel and oil supply

2.3.6.1 A flight shall not be commenced unless, taking into account both the meteorological conditions and any delays that are expected in flight, the *aeroplane* carries sufficient fuel and oil to ensure that it can safely complete the flight. The amount of fuel to be carried must permit:

- a) when the flight is conducted in accordance with the instrument flight rules and a *destination alternate aerodrome* is not required in accordance with 2.3.5.1, flight to the *aerodrome* of intended landing, and after that, for at least 45 minutes at normal cruising altitude; or
- b) when the flight is conducted in accordance with the instrument flight rules and a *destination alternate aerodrome* is required, flight from the *aerodrome* of intended landing to an *alternate aerodrome*, and after that, for at least 45 minutes at normal cruising altitude; or
- c) when the flight is conducted in accordance with the visual flight rules by day, flight to the *aerodrome* of intended landing, and after that, for at least 30 minutes at normal cruising altitude; or
- d) when the flight is conducted in accordance with the visual flight rules by *night*, flight to the *aerodrome* of intended landing and thereafter for at least 45 minutes at normal cruising altitude.

2.3.7 Refuelling with passenger on board

2.3.7.1 An *aeroplane* shall not be refuelled when passengers are embarking, onboard or disembarking unless it is attended by the *pilot-in-command* or other qualified personnel ready to initiate and direct an evacuation of the *aeroplane* by the most practical and expeditious means available.

2.3.7.2 When refuelling with passengers embarking, on board or disembarking, two-way communications shall be maintained by the *aeroplane's* intercommunication system or other suitable means between the ground crew

supervising the refuelling and the *pilot-in-command* or other qualified personnel required by 2.3.7.1.

2.3.8 Oxygen supply

2.3.8.1 The *pilot-in-command* shall ensure that breathing oxygen is available to crew members and passengers in sufficient quantities for all flights at such altitudes where a lack of oxygen might result in impairment of the faculties of crew members or harmfully affect passengers.

Note.1. - Guidance on the carriage and use of oxygen is given in Appendix C of this chapter.

Note.2. - Approximate altitudes in the Standard Atmosphere corresponding to the values of absolute pressure used in the text of Appendix C as follows:

Absolute pressure	Metres	Feet
700 hPa	3 000	10 000
620 hPa	4 000	13 000
376 hPa	7 600	25 000

2.4 In-flight procedures

2.4.1 Aerodrome operating minima

2.4.1.1 A flight shall not be continued towards the *aerodrome* of intended landing, unless the latest available information indicates that at the expected time of arrival, a landing can be effected at that *aerodrome* or at least one *destination alternate aerodrome*, in compliance with the operating minima.

2.4.1.2 An instrument approach shall not be continued beyond the outer marker fix in case of precision approach, or below 300 m (1000 ft) above the *aerodrome* in case of *non-precision approach*, unless the reported visibility or controlling RVR is above the specified minimum.

2.4.1.3 If, after passing the outer marker fix in case of precision approach, or after descending below 300 m (1000 ft) above the *aerodrome* in case of *non-precision approach*, the reported visibility or controlling RVR falls below the specified minimum, the approach may be continued to DA/H or MDA/H. In any case, an *aeroplane* shall not continue its approach-to-land beyond a point at which the limits of the *aerodrome operating minima* would be infringed.

2.4.2 Weather reporting by pilots

2.4.2.1 When weather conditions likely to affect the safety of other *aircraft* are encountered, they shall be reported as soon as possible.

2.4.3 Hazardous flight conditions

2.4.3.1 Hazardous flight conditions encountered, other than those associated with meteorological conditions, shall be reported to the appropriate aeronautical station as soon as possible. The reports so rendered shall give such details as may be pertinent to the safety of other *aircraft*.

2.4.4 Flight crew members at duty stations

2.4.4.1 Take-off and landing. All *flight crew members* required to be on flight deck duty shall be at their stations.

2.4.4.2 En route. All *flight crew members* required to be on flight deck duty shall remain at their stations except when their absence is necessary for the performance of duties in connection with the operation of the *aeroplane* or for physiological needs.

2.4.4.3 Seat belts. All *flight crew members* shall keep their seat belts fastened when at their stations.

2.4.4.4 Safety harness. When safety harnesses are provided, any *flight crew member* occupying a pilot's seat shall keep the safety harness fastened during the take-off and landing phases; all other *flight crew members* shall keep their safety harnesses fastened during the take-off and landing phases unless the shoulder straps interfere with the performance of their duties, in which case the shoulder straps may be unfastened but the seat belt must remain fastened.

2.4.5 Use of oxygen

2.4.5.1 All *flight crew members*, when engaged in performing duties essential to the safe operation of an *aeroplane* in flight, shall use breathing oxygen continuously whenever the circumstances prevail for which its supply has been prescribed in paragraph 2.3.8.

2.4.6 Safeguarding of cabin crew and passengers in pressurised aeroplanes in the event of loss of pressurisation

2.4.6.1 A flight shall not be commenced unless cabin crew are safeguarded so as to ensure reasonable probability of their retaining consciousness during any emergency descent which may be necessary in the event of loss of pressurisation and, in addition, they shall have such means of protection as will enable them to administer first aid to passengers during stabilised flight following the emergency. Passengers shall also be safeguarded by such devices or operational procedures as will ensure reasonable probability of their surviving the effects of hypoxia in the event of loss of pressurisation.

2.5 Duties of pilot-in-command

2.5.1 The *pilot-in-command* of a Singapore *aeroplane* to which this Chapter applies shall be responsible for –

- a) the operation, safety and security of the *aeroplane* and the safety of all crew members, passengers and cargo on board;
- b) ensuring that a flight –
 - i) will not be commenced if any *flight crew member* is incapacitated from performing duties by any cause

such as injury, sickness, fatigue, the effects of any psychoactive substance; and

- ii) will not be continued beyond the nearest suitable *aerodrome* when *flight crew members'* capacity to perform functions is significantly reduced by impairment of faculties from causes such as fatigue, sickness or lack of oxygen
- c) notifying the nearest appropriate authority by the quickest available means of any *accident* involving the *aeroplane*, resulting in serious injury or death of any person or substantial damage to the *aeroplane* or property.

2.6 Cabin baggage (take-off and landing)

- 2.6.1 The *pilot-in-command* shall ensure that all baggage carried onto an *aeroplane* and taken into the passenger cabin is securely stowed.

3 AEROPLANE PERFORMANCE OPERATING LIMITATIONS

3.1 General

- 3.1.1 A flight shall not be commenced unless the *aeroplane* operated is:
- a) in compliance with the terms of its airworthiness certificate or equivalent approved document;
 - b) within the operating limitations prescribed by the *Chief Executive*; and
 - c) if applicable, within the mass limitations imposed by compliance with the applicable noise certificate issued by the *Chief Executive*, unless otherwise authorised in exceptional circumstances for a certain *aerodrome* or a runway where there is no noise disturbance problem, by the competent authority of the State in which the *aerodrome* is situated.
- 3.1.2 A flight shall not be commenced unless placards, listings, instrument markings, or combinations thereof, containing those operating limitations prescribed by the *Chief Executive* for visual presentation, are displayed in the *aeroplane*.
- 3.1.3 The *pilot-in-command* shall determine that *aeroplane* performance will permit the take-off and departure to be carried out safely.

4 AEROPLANE INSTRUMENTS, EQUIPMENT AND FLIGHT DOCUMENTS

4.1 General

4.1.1 In addition to the minimum equipment necessary for the issuance of a certificate of airworthiness, an *aeroplane* shall not fly unless the instruments, equipment and flight documents prescribed in the following paragraphs are installed or carried, as appropriate, in *aeroplanes* according to the *aeroplane* used and to the circumstances under which the flight is to be conducted. The prescribed instruments and equipment, including their installation, shall be acceptable to the *Chief Executive*.

4.2 Aeroplanes on all flights

4.2.1 A flight shall not be commenced unless the *aeroplane* is equipped with instruments which will enable the flight crew to control the flight path of the *aeroplane*, carry out any required procedural manoeuvres and observe the operating limitations of the *aeroplane* in the expected operating conditions.

4.2.2 *Aeroplanes* on all flights shall be equipped with:

- a) an accessible first-aid kit;
- b) portable fire extinguishers of a type which, when discharged, will not cause dangerous contamination of the air within the *aeroplane*. At least one shall be located in:
 - i) the pilot's compartment; and
 - ii) each passenger compartment that is separate from the pilot's compartment and not readily accessible to the pilot or co-pilot;
- c)
 - i) a seat or berth for each person over an age of two years ; and
 - ii) a seat belt for each seat and restraining belts for each berth;
- d) the following manuals, charts and information
 - i) the *flight manual* or other documents or information concerning any operating limitations prescribed for the *aeroplane* by the *Chief Executive*, required for the application of Chapter 2.3;
 - ii) current and suitable charts for the route of the proposed flight and all routes along which it is reasonable to expect that the flight may be diverted;
 - iii) procedures for pilots-in-command of intercepted *aircraft*; unless the flight is intended not include passage over the territory of any country other than

- iv) Singapore. However, if there is a possibility of the flight inadvertently straying over the territory of another country, these procedures should be carried on board;
 - v) visual signals for use by intercepting and intercepted aircraft, and
 - vi) the journey log book for the *aeroplane*; unless the flight is intended to begin and end at the same *aerodrome* and does not include passage over the territory of any country other than Singapore.
- e) where the *aeroplane* is fitted with fuses that are accessible in flight, spare electrical fuses of appropriate ratings for replacement of those fuses.

4.2.3 *Aeroplanes* on all flights shall be equipped with the ground-air signal codes for search and rescue purposes.

4.2.4 *Aeroplanes* on all flights shall be equipped with a safety harness for each *flight crew member* seat. Safety harness includes shoulder strap(s) and a seat belt which may be used independently.

4.2.5 Marking of break- in points

4.2.5.1 If areas of the fuselage suitable for break-in by rescue crews in emergency are marked on an *aeroplane* such areas shall be marked as shown below (see figure following). The colour of the markings shall be red or yellow, and if necessary they shall be outlined in white to contrast with the background.

4.2.5.2 If the corner markings are more than 2 m apart, intermediate lines 9 cm x 3 cm shall be inserted so that there is no more than 2 m between adjacent markings.

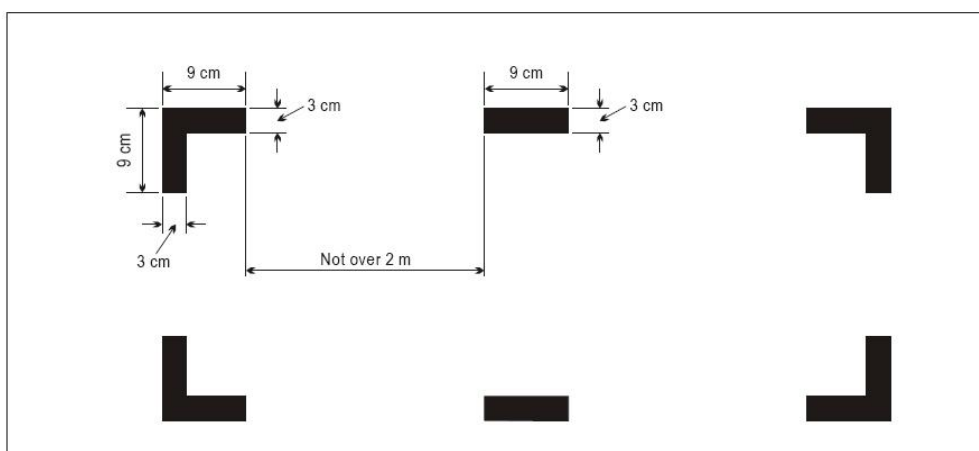

MARKINGS OF BREAK-IN POINTS

4.3 Aeroplanes operated as VFR flights

4.3.1 A VFR flight shall not be commenced unless the *aeroplane* is equipped with:

- a) a means of measuring and displaying:
 - i) magnetic heading;
 - ii) the time in hours, minutes and seconds;
 - iii) pressure altitude;
 - iv) indicated airspeed; and
- b) such additional equipment as may be prescribed by the appropriate authority.

4.4 Aeroplanes on flights over water

4.4.1 Seaplanes

4.4.1.1 Seaplanes for all flights shall be equipped with:

- a) one life jacket, or equivalent individual floatation device, for each person on board, stowed in a position readily accessible from the seat or berth;
- b) equipment for making the sound signals prescribed in the International Regulations for Preventing Collisions at Sea, where applicable;
- c) one anchor; and
- d) one sea anchor (drogue), when necessary to assist in manoeuvring.

4.4.2 Landplanes

4.4.2.1 All single-engine landplanes:

A flight operated with a single-engine landplane shall not be commenced if its intended flight path includes

- a) flying en route over water beyond gliding distance from the shore; or
- b) taking off or landing at an *aerodrome* where, in the opinion of the *pilot-in-command*, the take-off or approach path is so disposed over water that in the event of a mishap there would be a likelihood of a ditching;

unless the *aeroplane* is equipped with one life jacket or equivalent individual floatation device for each person on board, stowed in a position easily accessible from the seat or berth of the person for whose use it is provided.

Note. - “Landplanes” includes amphibians operated as landplanes.

4.4.3 Aeroplanes on extended flights over water

4.4.3.1 All *aeroplanes* operated on extended flights over water shall be equipped with, at a minimum, one life jacket or equivalent individual floatation device for each person on board, stowed in a position easily accessible from the seat or berth of the person for whose use it is provided.

4.4.3.2 The *pilot-in-command* of an *aeroplane* operated on an extended flight over water shall determine the risks to survival of the occupants of the *aeroplane* in the event of a ditching. The *pilot-in-command* shall take into account the operating environment and conditions such as, but not limited to, sea state and sea and air temperatures, the distance from land suitable for making an emergency landing, and the availability of search and rescue facilities. Based upon the assessment of these risks, the *pilot-in-command* shall, in addition to the equipment required in 4.4.3.1, ensure that the flight is only commenced if the *aeroplane* is equipped with:

- a) life-saving rafts in sufficient numbers to carry all persons on board, stowed so as to facilitate their ready use in emergency, provided with such lifesaving equipment, including means of sustaining life, as is appropriate to the flight to be undertaken; and
- b) equipment for making the distress signals.

4.5 Aeroplanes on flights over designated land areas

4.5.1 A flight across land areas which have been designated by the State concerned as areas in which search and rescue would be especially difficult, shall not be commenced unless the *aeroplane* is equipped with such signalling devices and lifesaving equipment (including means of sustaining life) as may be appropriate to the area overflown.

4.6 Aeroplanes on high altitude flights

4.6.1 An *aeroplane* shall not be operated at high altitudes unless it is equipped with oxygen storage and dispensing apparatus capable of storing and dispensing the oxygen supplies required in paragraph 2.3.8.

4.6.2 A pressurised *aeroplanes* shall not be operated at flight altitudes at which the atmospheric pressure is less than 376 hPa unless it is equipped with a device to provide positive warning to the flight crew of any dangerous loss of pressurisation.

4.7 Aeroplanes operated in accordance with the instrument flight rules

4.7.1 *Aeroplanes* when operated in accordance with the instrument flight rules, or when the *aeroplane* cannot be maintained in a desired attitude without reference to one or more flight instruments, shall be equipped with:

- a) a means of measuring and displaying:
- i) magnetic heading (standby compass);
 - ii) the time in hours, minutes and seconds;
 - iii) pressure altitude;
 - iv) indicated airspeed, with a means of preventing malfunctioning due to either condensation or icing;
 - v) turn and slip;
 - vi) *aircraft* attitude; and
 - vii) stabilised *aircraft* heading;
- Note. - The requirements of v), vi) and vii) may be met by combinations of instruments or by integrated flight director systems provided that the safeguards against total failure, inherent in the three separate instruments, are retained.*
- viii) whether the supply of power to the gyroscopic instruments is adequate;
 - ix) the outside air temperature;
 - x) rate-of-climb and descent; and
- b) such additional instruments or equipment as may be prescribed by the *Chief Executive*.

4.8 Aeroplanes when operated at night

4.8.1 An *aeroplane* shall not be operated at *night*, unless it is equipped with:

- a) the equipment specified in 4.7; and
- b) navigation and anti-collision lights for *aircraft* in flight or operating on the movement area of an *aerodrome*;
- c) a landing light;
- d) illumination for all flight instruments and equipment that are essential for the safe operation of the *aeroplane* that are used by the flight crew;
- e) lights in all passenger compartments; and
- f) an independent portable light for each crew member station.

Note. - Specifications for lights to be displayed by aeroplanes are in Appendix A and the Eleventh Schedule of the Air Navigation Order.

4.9 Aeroplanes complying with Part VI of Air Navigation Order

4.9.1 An *aeroplane* to which Part VI of the Air Navigation Order applies shall be required to comply with the requirements specified therein and the requirements specified in the Tenth Schedule of the Air Navigation Order.

4.10 Mach number indicator

4.10.1 A flight operated with an *aeroplane* with speed limitations expressed in terms of Mach number shall not be commenced unless the *aeroplane* is equipped with a means of displaying Mach number.

4.11 Aeroplanes required to be equipped with ground proximity warning systems (GPWS)

4.11.1 A flight operated with turbined-engined *aeroplanes* of a maximum certificated take-off mass in excess of 5700 kg or authorised to carry more than nine passengers shall not be commenced unless the *aeroplanes* are equipped with a ground proximity warning system which has a forward-looking terrain avoidance function.

4.11.2 A flight operated with all piston-engined *aeroplanes* of a maximum certificated take-off mass of 5700 kg or less and authorised to carry more than five but not more than nine passengers shall not be commenced unless the *aeroplanes* are equipped with a ground proximity warning system which has a forward-looking terrain avoidance function.

4.11.3 A ground proximity warning system shall provide automatically a timely and distinctive warning to the flight crew when the *aeroplane* is in potentially hazardous proximity to the earth's surface.

4.11.4 A ground proximity warning system shall provide, as a minimum, warnings of at least the following circumstances:

- a) excessive descent rate;
- b) excessive altitude loss after take-off or go-around;
- c) unsafe terrain clearance.

4.11.5 A ground proximity warning system installed in turbine – engined *aeroplanes* of a maximum certificated take-off mass in excess of 5700 kg or authorised to carry more than nine passengers for which the individual certificate of airworthiness was first issued after 1 January 2011 shall provide, as a minimum, warning of at least the following circumstances:

- a) excessive descent rate
- b) excessive terrain closure rate
- c) excessive altitude loss after take-off or go-around
- d) unsafe terrain clearance while not in landing configuration
 - i) gear not locked down
 - ii) flaps not in a landing position; and
- e) excessive descent below the instrument glide path.

4.12 *Emergency locator transmitter (ELT)*

4.12.1 A flight shall not be commenced unless the *aeroplane* is equipped with an automatic emergency locator transmitter (ELT).

4.13 *Aeroplanes required to be equipped with a pressure-altitude reporting transponder*

4.13.1 A flight shall not be commenced unless the *aeroplane* is equipped with a pressure-altitude reporting transponder which operates in accordance with the relevant provisions of Annex 10 to the Convention on International Civil Aviation, Volume IV.

4.13.2 A VFR flight shall not be commenced unless the *aeroplane* is equipped with a pressure-altitude reporting transponder which operates in accordance with the relevant provision of Annex 10 to the Convention on International Civil Aviation, Volume IV.

4.14 *Microphones*

4.14.1 When operating under the instrument flight rules all *flight crew members* required to be on flight deck duty shall communicate through boom or throat microphones below the transition level/altitude.

4.15 *Aeroplanes equipped with head-up displays (HUD) and/or enhanced vision system (EVS)*

4.15.1 Where a Singapore *aeroplane* is equipped with *HUD* and/or *EVS*, such systems shall not be used to gain operational benefits unless approved by the Chief Executive.

Note. – Guidance on HUB and EVS is contained in relevant advisory circulars.

5 AEROPLANE COMMUNICATION AND NAVIGATION EQUIPMENT

5.1 Communication equipment

- 5.1.1 An *aeroplane* shall not be operated in accordance with the instrument flight rules or at *night* unless it is provided with radio communication equipment. Such equipment shall be capable of conducting two-way communication with those aeronautical stations and on those frequencies prescribed by the *Chief Executive*.
- 5.1.2 When compliance with 5.1.1 requires that more than one communication equipment unit be provided, each shall be independent of the other or others to the extent that a failure in any one will not result in failure of any other.
- 5.1.3 An *aeroplane* shall not be operated in accordance with the visual flight rules as a controlled flight, unless it is provided with radio communication equipment capable of conducting two-way communication at any time during flight with such aeronautical stations and on such frequencies as may be prescribed by the *Chief Executive*. This requirement applies unless when it is exempted by the *Chief Executive*.
- 5.1.4 An *aeroplane* shall not be operated on extended flights over water or across land areas which have been designated by the State concerned as areas in which search and rescue would be especially difficult, unless it is provided with radio communication equipment capable of conducting two-way communication at any time during flight with such aeronautical stations and on such frequencies as may be prescribed by the *Chief Executive*.
- 5.1.5 The radio communication equipment required in accordance with 5.1.1 to 5.1.4 shall provide for communication on the aeronautical emergency frequency 121.5 MHz.
- 5.1.6 For flight operations in defined portions of airspace or on routes where an RCP type has been prescribed, an *aeroplane* shall, in addition to the requirements specified in 5.1.1 to 5.1.5:
- a) be provided with communication equipment which will enable it to operate in accordance with the prescribed RCP type(s); and
 - b) be authorised by the *Chief Executive* for such operations.

5.2 Navigation equipment

- 5.2.1 A flight shall not be commenced unless the *aeroplane* is provided with navigation equipment which will enable it to proceed
- a) in accordance with the *flight plan*; and
 - b) in accordance with the requirements of air traffic services; except when, if not so precluded by the appropriate authority, navigation for flights under the visual flight rules is accomplished by visual reference to landmarks.

- 5.2.2 For operations where a navigation specification for PBN has been prescribed, an *aeroplane* shall, in addition to the requirements specified in 5.2.1:
- a) be provided with navigation equipment which will enable it to operate in accordance with the prescribed navigation specification(s); and
 - b) be authorised by the *Chief Executive* for such operations.
- 5.2.3 A flight in defined portions of airspace where, based on regional air navigation agreement, minimum navigation performance specifications (MNPS) are prescribed, shall not be commenced unless the *aeroplane* is provided with navigation equipment which:
- a) continuously provides indications to the flight crew of adherence to or departure from track to the required degree of accuracy at any point along that track; and
 - b) has been authorised by the *Chief Executive* for MNPS operations concerned.
- 5.2.4 A flight in defined portions of airspace where, based on regional air navigation agreement, a reduced vertical separation minimum (RVSM) of 300 m (1000 ft) is applied between FL 290 and FL 410 inclusive, shall not be commenced unless the *aeroplane*:
- a) is provided with equipment which is capable of:
 - i) indicating to the flight crew the flight level being flown;
 - ii) automatically maintaining a selected flight level;
 - iii) providing an alert to the flight crew when a deviation occurs from the selected flight level. The threshold for the alert shall not exceed ± 90 m (300 ft); and
 - iv) automatically reporting pressure-altitude; and
 - b) is authorised by the *Chief Executive* for operation in the airspace concerned; and
 - c) Shall demonstrate a vertical navigation performance in accordance with Appendix B
- 5.2.5 An *operator* of a Singapore *aeroplane* to which this Chapter applies shall:
- a) ensure that the vertical navigation performance capability of the *aeroplane* satisfies the requirements specified in Appendix B;
 - b) institute appropriate procedures in respect of continued airworthiness (*maintenance* and *repair*) practices and programmes; and

- c) institute appropriate flight crew procedures for operations in RVSM airspace.

5.2.6 The *aeroplane* shall be sufficiently provided with navigation equipment to ensure that, in the event of the failure of one item of equipment at any stage of the flight, the remaining equipment will enable the *aeroplane* to navigate in accordance with 5.2.1 and where applicable 5.2.2, 5.2.3 and 5.2.4.

5.2.7 A flight in which is intended to land in instrument meteorological conditions shall not be commenced, unless the *aeroplane* is provided with radio equipment capable of receiving signals providing guidance to a point from which a visual landing can be effected. This equipment shall be capable of providing such guidance for each *aerodrome* at which it is intended to land in instrument meteorological conditions and for any designated *alternate aerodromes*.

5.2.8 With effect from 18 November 2010, the operator with RVSM operational approval shall set in place a programme to ensure that a minimum of two *aeroplanes* of each *aeroplane*-type grouping have their height-keeping performance monitored at least once every two years or within intervals of 1000 flight hours per *aeroplane*, whichever period is the longer. If the operator's *aeroplane*-type grouping consists of a single *aeroplane*, monitoring of that *aeroplane* shall be accomplished within the specific period.

Note. – *Monitoring data from any regional monitoring programme established in accordance with ICAO Annex 11, 3.3.5.2, may be used to satisfy the requirement. Additional guidance is provided via relevant advisory circulars on the respective operations.*

6 AEROPLANE MAINTENANCE

6.1 Owner's *maintenance* responsibilities

6.1.1 The owner of an *aeroplane*, or in the case where it is leased, the lessee, shall ensure that, in accordance with procedures acceptable to the *Chief Executive*:

- a) the *aeroplane* is maintained in an airworthy condition;
- b) the operational and emergency equipment necessary for an intended flight is serviceable; and
- c) the Certificate of Airworthiness of the *aeroplane* remains valid.

6.1.2 The owner or the lessee shall not operate the *aeroplane* unless it is maintained and released to service under a system acceptable to the *Chief Executive*.

6.1.3 When the *maintenance release* is not issued by an approved maintenance organisation, the person signing the *maintenance release* shall be licensed and approved by the *Chief Executive*.

6.1.4 The owner or the lessee shall ensure that the *maintenance* of the *aeroplane* is performed in accordance with a *maintenance* programme acceptable to the *Chief Executive*.

6.2 *Maintenance* records

6.2.1 The owner of an *aeroplane*, or in the case where it is leased, the lessee, shall ensure that the following records are kept for the periods mentioned in 6.2.2:

- a) the total time in service (hours, calendar time and cycles, as appropriate) of the *aeroplane* and all life limited components;
- b) the current status of compliance with all applicable mandatory continuing airworthiness information;
- c) appropriate details of modifications and *repairs*;
- d) the time in service (hours, calendar time and cycles, as appropriate) since the last overhaul of the *aeroplane* or its components subject to a mandatory overhaul life;
- e) the current status of the *aeroplane's* compliance with the *maintenance* programme; and
- f) the detailed *maintenance* records to show that all requirements for the signing of a *maintenance release* have been met.

6.2.2 The records shall be kept for a minimum period of 2 years after the unit to which they refer has been permanently withdrawn from service.

6.2.3 In the event of a temporary change of owner or lessee, the records shall be made available to the new owner or lessee. In the event of any permanent

change of owner or lessee, the records shall be transferred to the new owner or lessee.

6.3 Modifications and repairs

6.3.1 An *aeroplane* shall not fly unless all modifications and *repairs* carried out comply with the requirements contained in the ANO and the SAR.

6.4 Maintenance release

6.4.1 An *aeroplane* shall not fly unless a *maintenance release* is completed and signed to certify that the *maintenance* work performed has been completed satisfactorily and in accordance with data and procedures acceptable to the *Chief Executive*.

6.4.2 A *maintenance release* shall contain a certification including:

- a) basic details of the *maintenance* performed;
- b) the date such *maintenance* was completed;
- c) when applicable, the identity of the approved maintenance organisation; and
- d) the identity of the authorised person or persons signing the release.

7 AEROPLANE FLIGHT CREW

7.1 Composition of the *flight crew*

7.1.1 A flight shall not be commenced unless the number and composition of the flight crew is no less than that specified in the *flight manual* or other documents associated with the certificate of airworthiness.

7.2 Qualifications

7.2.1 The *pilot-in-command* of a Singapore *aeroplane* to which this Chapter applies shall:

- a) ensure that each *flight crew member* holds a valid licence issued by the *Chief Executive*;
- b) ensure that *flight crew members* are properly rated;
- c) be satisfied that *flight crew members* have maintained competency;
and
- d) ensure that each *flight crew member* has been appropriately trained to competency in the use of ACAS II equipment and the avoidance of collision, if the *aeroplane* is equipped with an airborne collision avoidance system (ACAS II).

8 MANUALS, LOGS AND RECORDS

8.1 *Flight manual*

8.1.1 An *operator* of a Singapore *aeroplane* to which this Chapter applies shall ensure that the *aeroplane flight manual* is updated by implementing changes made mandatory by the *aircraft* manufacturer and/or by the *Chief Executive*.

8.2 Journey log / Technical log book

8.2.1 An *operator* of a Singapore *aeroplane* to which this Chapter applies shall ensure that a journey log / technical log book is maintained for every *aeroplane* engaged in international air navigation in which shall be entered particulars of the *aeroplane*, its crew and each journey.

8.2.2 The *aeroplane* journey / technical log shall contain the following items:

- a) *aeroplane* nationality and registration;
- b) date;
- c) crew member names and duty assignments;
- d) departure and arrival points and times;
- e) purpose of flight;
- f) observations regarding the flight; and
- g) signature of the *pilot-in-command*.

8.3 Records of emergency and survival equipment carried

8.3.1 An *operator* of a Singapore *aeroplane* to which this Chapter applies, shall at all times have available for immediate communication to rescue coordination centres, lists containing information on the emergency and survival equipment carried on board the *aeroplane* engaged in international air navigation. The information shall include, as applicable, the number, colour and type of life rafts and pyrotechnics, details of emergency medical supplies, water supplies and the type and frequencies of the emergency portable radio equipment.

9 SECURITY

9.1 Security of aircraft

9.1.1 The *pilot-in-command* shall be responsible for the security of the *aircraft* during its operation.

9.2 Reporting acts of unlawful interference

9.2.1 Following an act of unlawful interference, the *pilot-in-command* shall submit a report of such an act to the *Chief Executive*.

CHAPTER 3
LARGE / TURBINE-POWERED *AEROPLANES* AND
CORPORATE AVIATION OPERATIONS

EFFECTIVE DATE : 18 NOVEMBER 2010

REVISION NO : 1 (ISSUE 1)

1 RESERVED

2 RESERVED

3 GENERAL

3.1 Compliance with laws, regulations and procedures

3.1.1 An *operator* of a Singapore *aeroplane* to which this Chapter applies shall -

- a) ensure that all employees know that they must comply with the laws, regulations and procedures of Singapore and those States in which the operations are conducted;
- b) ensure that all pilots are familiar with the laws, regulations and procedures, pertinent to the performance of their duties, prescribed for the areas to be traversed, the *aerodromes* to be used and the air navigation facilities relating thereto. The *operator* shall ensure that other members of the flight crew are familiar with such of these laws, regulations and procedures as are pertinent to the performance of their respective duties in the operation of the *aeroplane*;
- c) describe the *operational control* system in the *operations manual* and identify the roles and responsibilities of those involved with the system,
- d) ensure that the *pilot-in-command* has available on board the *aeroplane* all the essential information concerning the search and rescue services in the area over which the *aeroplane* will be flown, and
- e) ensure that *flight crew members* are appropriately licensed and have met the language proficiency requirements as spelt out in SASP 1 and SASP 2.

3.1.2 The *pilot-in-command* is responsible for *operational control*.

3.2 Safety management system

3.2.1 An *operator* of a Singapore *aeroplane* to which this Chapter applies shall establish and maintain a safety management system that is appropriate to the size and complexity of the operation.

3.2.2 The safety management system shall as minimum include:

- a) a process to identify actual and potential safety hazards and assess the associated risks;
- b) a process to develop and implement remedial action necessary to maintain an acceptable level of safety; and
- c) provision for continuous monitoring and regular assessment of the appropriateness and effectiveness of safety management activities.

4 FLIGHT OPERATIONS

4.1 Operating facilities

- 4.1.1 An *operator* of a Singapore *aeroplane* to which this Chapter applies shall ensure that a flight will not be commenced unless it has been ascertained by every reasonable means available that the ground and/or water facilities including communication facilities and navigation aids available and directly required on such flight, for the safe operation of the *aeroplane*, are adequate for the type of operation under which the flight is to be conducted.

Note. - “Reasonable means” in these Requirements is intended to denote the use, at the point of departure, of information available to the operator either through official information published by the aeronautical information services or readily obtainable from other sources.

4.2 Operational management

4.2.1 Operator notification

- 4.2.1.1 If a Singapore *operator* has an *operating base* in a State other than the Republic of Singapore, the Singapore *operator* shall notify the State in which the *operating base* is located. Upon such notification, the safety and security oversight shall be coordinated between the State in which the *operating base* is located and the *Chief Executive*.

4.2.2 Operations manual

- 4.2.2.1 An *operator* of a Singapore *aeroplane* to which this Chapter applies shall provide, for the use and guidance of personnel concerned, an *operations manual* containing all the instructions and information necessary for operations personnel to perform their duties. The *operations manual* shall be amended or revised as is necessary to ensure that the information contained therein is kept up to date. All such amendments or revisions shall be issued to all personnel that are required to use this manual.

Note.1 - Appendix D contains guidance on the organisation and content of an operations manual.

4.2.3 Operating instructions — general

- 4.2.3.1 An *operator* of a Singapore *aeroplane* to which this Chapter applies shall
- a) ensure that all operations personnel are properly instructed in their particular duties and responsibilities and the relationship of such duties to the operation as a whole; and
 - b) issue operating instructions and provide information on *aeroplane* climb performance to enable the *pilot-in-command* to determine the climb gradient that can be achieved during the departure phase for the

- c) existing take-off conditions and intended take-off technique. This information shall be included in the *operations manual*.

4.2.4 In-flight simulation of emergency situations

- 4.2.4.1 An *operator* of a Singapore *aeroplane* to which this Chapter applies shall ensure that when passengers are being carried, no emergency or abnormal situations shall be simulated.

4.2.5 Checklists

- 4.2.5.1 An *operator* of a Singapore *aeroplane* to which this Chapter applies shall provide checklists to be used by flight crews prior to, during and after all phases of operations, and in emergencies, to ensure compliance with the operating procedures contained in the *aircraft operating manual* and the *aeroplane flight manual* or other documents associated with the certificate of airworthiness and otherwise in the *operations manual*, are followed. The design and utilisation of checklists shall observe Human Factors principles.

4.2.6 Minimum flight altitudes

- 4.2.6.1 An *operator* of a Singapore *aeroplane* to which this Chapter applies shall specify, for flights which are to be conducted in accordance with the instrument flight rules, the method of establishing terrain clearance altitudes.

4.2.7 Aerodrome operating minima

- 4.2.7.1 An *operator* of a Singapore *aeroplane* to which this Chapter applies shall ensure that no *pilot-in-command* operates to or from an *aerodrome* using operating minima lower than those which may be established for that *aerodrome*.

Note. – Operations with lower visibilities than normally associated with the *aerodrome operating minima* may only be allowed on an *aeroplane* with HUB and/or EVS if approval has been obtained in accordance to Chapter 2, paragraph 4.15.1.

4.2.8 Fatigue management programme

- 4.2.8.1 An *operator* of a Singapore *aeroplane* to which this Chapter applies shall establish and implement a fatigue management programme that ensures that all personnel involved in the operation and *maintenance* of *aircraft* do not carry out their duties when fatigued. The programme shall address flight and duty times and be included in the *operations manual*.

4.2.9 Passengers

- 4.2.9.1 An *operator* of a Singapore *aeroplane* to which this Chapter applies shall ensure that passengers are made familiar with the location and use of:
 - a) seat belts;
 - b) emergency exits;

- c) life jackets, if the carriage of life jackets is prescribed;
- d) oxygen dispensing equipment, if the provision of oxygen for the use of passengers is prescribed; and
- e) other emergency equipment provided for individual use, including passenger emergency briefing cards.

4.2.9.2 An *operator* of a Singapore *aeroplane* to which this Chapter applies shall ensure that

- a) all persons on board are aware of the location and general manner of use of the principal emergency equipment carried for collective use;
- b) in an emergency during flight, passengers are instructed in such emergency action as may be appropriate to the circumstances; and
- c) during take-off and landing and whenever considered necessary, by reason of turbulence or any emergency occurring during flight, all passengers on board an *aeroplane* are secured in their seats by means of the seat belts or harnesses provided.

4.3 Flight preparation

4.3.1 An *operator* of a Singapore *aeroplane* to which this Chapter applies shall develop procedures to ensure that a flight is not commenced unless:

- a) the *aeroplane* is airworthy, duly registered and that appropriate certificates with respect thereto are aboard the *aeroplane*;
- b) the instruments and equipment installed in the *aeroplane* are appropriate, taking into account the expected flight conditions;
- c) any necessary *maintenance* has been performed in accordance with paragraph 8 of this Chapter.
- d) the mass of the *aeroplane* and centre of gravity location are such that the flight can be conducted safely, taking into account the flight conditions expected;
- e) any load carried is properly distributed and safely secured; and
- f) the *aeroplane* operating limitations, contained in the *flight manual*, or its equivalent, will not be exceeded.

4.3.2 An *operator* of a Singapore *aeroplane* to which this Chapter applies shall make available sufficient information on climb performance with all engines operating to enable determination of the climb gradient that can be achieved during the departure phase for the existing take-off conditions and intended take-off technique.

4.3.3 Operational flight planning

4.3.3.1 An *operator* of a Singapore *aeroplane* to which this Chapter applies shall specify flight planning procedures to provide for the safe conduct of the flight based on considerations of *aeroplane* performance, other operating limitations and relevant expected conditions on the route to be followed and at the

aerodromes concerned. These procedures shall be included in the *operations manual*.

4.3.4 Alternate Aerodromes - Take-off alternate aerodrome

4.3.4.1 A flight shall not be commenced unless a *take-off alternate aerodrome* is selected and specified in the *flight plan* if the weather conditions at the *aerodrome* of departure are at or below the applicable *aerodrome operating minima* or it would not be possible to return to the *aerodrome* of departure for other reasons.

4.3.4.2 The *take-off alternate aerodrome* shall be located within the following distance from the *aerodrome* of departure:

- a) *aeroplanes* having two power-units. Not more than a distance equivalent to a *flight time* of one hour at the single-engine cruise speed; and
- b) *aeroplanes* having three or more power-units. Not more than a distance equivalent to a *flight time* of two hours at the one-engine inoperative cruise speed.

4.3.4.3 For an *aerodrome* to be selected as a *take-off alternate* the available information shall indicate that, at the estimated time of use, the conditions will be at or above the *aerodrome operating minima* for that operation.

4.3.5 Refuelling with passengers on board

4.3.5.1 An *aeroplane* shall not be refuelled when passengers are embarking, on board or disembarking unless it is properly attended by qualified personnel ready to initiate and direct an evacuation of the *aeroplane* by the most practical and expeditious means available.

4.3.5.2 When refuelling with passengers embarking, on board or disembarking, two-way communication shall be maintained by the *aeroplane's* intercommunication system or other suitable means between the ground crew supervising the refuelling and the qualified personnel on board the *aeroplane*.

Note.1 - Additional precautions are required when refuelling with fuels other than aviation kerosene or when refuelling results in a mixture of aviation kerosene with other aviation turbine fuels, or when an open line is used.

4.3.6 Oxygen supply

- 4.3.6.1 A flight to be operated at flight altitudes at which the atmospheric pressure in personnel compartments will be less than 700 hPa shall not be commenced unless sufficient stored breathing oxygen is carried to supply:
- a) all crew members and 10 per cent of the passengers for any period in excess of 30 minutes that the pressure in compartments occupied by them will be between 700 hPa and 620 hPa; and
 - b) the crew and passengers for any period that the atmospheric pressure in compartments occupied by them will be less than 620 hPa.
- 4.3.6.2 A flight to be operated with a pressurised *aeroplane* shall not be commenced unless a sufficient quantity of stored breathing oxygen is carried to supply all the crew members and passengers, as is appropriate to the circumstances of the flight being undertaken, in the event of loss of pressurisation, for any period that the atmospheric pressure in any compartment occupied by them would be less than 700 hPa. In addition, when an *aeroplane* is operated at flight altitudes at which the atmospheric pressure is less than 376 hPa, or which, if operated at flight altitudes at which the atmospheric pressure is more than 376 hPa and cannot descend safely within four minutes to a flight altitude at which the atmospheric pressure is equal to 620 hPa, there shall be no less than a 10-minute supply for the occupants of the passenger compartment.

4.4 In-flight procedures

4.4.1 Instrument approaches

- 4.4.1.1 An *operator* of a Singapore *aeroplane* to which this Chapter applies shall include operating procedures for conducting instrument approaches in the *aircraft operations manual*.

4.4.2 Use of oxygen

- 4.4.2.1 All *flight crew members*, when engaged in performing duties essential to the safe operation of an *aeroplane* in flight, shall use breathing oxygen continuously whenever the circumstances prevail for which its supply has been required in 4.3.6.1 or 4.3.6.2 .
- 4.4.2.2 All *flight crew members* of pressurised *aeroplanes* operating above an altitude where the atmospheric pressure is less than 376 hPa shall have available at the flight duty station a quick-donning type of oxygen mask which will readily supply oxygen upon demand.

4.4.3 Aeroplane operating procedures for noise abatement

- 4.4.3.1 Noise abatement procedures specified by an *operator* of a Singapore *aeroplane* to which this Chapter applies for any one *aeroplane* type shall be the same for all *aerodromes*.

Note. - Appendix F contains procedures for noise abatement

3.4.4 *Aeroplane operating procedures for rates of climb and descent*

3.4.4.1 Unless otherwise specified in an air traffic control instruction, to avoid unnecessary airborne collision avoidance system (ACAS II) resolution advisories in *aircraft* at or approaching adjacent altitudes or flight levels, pilots shall consider using appropriate procedures to ensure that a rate of climb or descent of less than 8 m/sec or 1 500 ft/min (depending on the instrumentation available) is achieved throughout the last 300 m (1 000 ft) of

climb or descent to the assigned altitude or flight level, when made aware of another *aircraft* at or approaching an adjacent altitude or flight level.

4.5 Duties of *pilot-in-command*

4.5.1 The *pilot-in-command* of a Singapore *aeroplane* to which this Chapter applies shall

- a) ensure that the checklists specified in para 4.2.5 are complied with;
- b) notify the nearest appropriate authority by the quickest available means of any *accident* involving the *aeroplane*, resulting in serious injury or death of any person or substantial damage to the *aeroplane* or property. In the event that the *pilot-in-command* is incapacitated the *operator* shall take the forgoing action;
- c) report all known or suspected defects in the *aeroplane*, to the *operator*, at the termination of the flight; and
- d) be responsible for the journey log / technical log book or the general declaration containing the information listed in Chapter 2 para 8.2.

4.6 Cabin baggage (take-off and landing)

4.6.1 An *operator* of a Singapore *aeroplane* to which this Chapter applies shall specify procedures to ensure that all baggage carried onto an *aeroplane* and taken into the passenger cabin is adequately and securely stowed.

5 AEROPLANE PERFORMANCE OPERATING LIMITATIONS

5.1 General

- 5.1.1 The requirements contained in 5.1.2 to 5.1.8 inclusive are applicable to all *aeroplanes* of over 5700 kg maximum certificated take-off mass.
- 5.1.2 All *aeroplane* shall be operated in compliance with the terms of its certificate of airworthiness and within the approved operating limitations contained in its *flight manual*.
- 5.1.3 A flight shall not be commenced unless the performance information provided in the *flight manual* indicates that the requirements of 5.1.4 to 5.1.8 can be complied with for the flight to be undertaken.
- 5.1.4 In applying the requirements of this Chapter, account shall be taken of all factors that significantly affect the performance of the *aeroplane* (such as: mass, operating procedures, the pressure-altitude appropriate to the elevation of the *aerodrome*, temperature, wind, runway gradient and condition of runway, i.e. presence of slush, water and/or ice, for landplanes, water surface condition for seaplanes). Such factors shall be taken into account directly as operational parameters or indirectly by means of allowances or margins, which may be provided in the scheduling of performance data or in the comprehensive and detailed code of performance in accordance with which the *aeroplane* is being operated.
- 5.1.5 Mass limitations
- 5.1.5.1 The mass of the *aeroplane* at the start of take-off shall not exceed the mass at which 5.1.6 is complied with, nor the mass at which 5.1.7 and 5.1.8 are complied with, allowing for expected reductions in mass as the flight proceeds, and for such fuel jettisoning as is envisaged in applying 5.1.7 and 5.1.8 and, in respect of *alternate aerodromes*, 5.1.5 c) and 5.1.8
- 5.1.5.2 In no case shall the mass at the start of take-off exceed the maximum take-off mass specified in the *flight manual* for the pressure-altitude appropriate to the elevation of the *aerodrome*, and if used as a parameter to determine the maximum take-off mass, any other local atmospheric condition.
- 5.1.5.3 In no case shall the estimated mass for the expected time of landing at the *aerodrome* of intended landing and at any *destination alternate aerodrome*, exceed the maximum landing mass specified in the *flight manual* for the pressure-altitude appropriate to the elevation of those *aerodromes*, and if used as a parameter to determine the maximum landing mass, any other local atmospheric condition.
- 5.1.5.4 In no case shall the mass at the start of take-off, or at the expected time of landing at the *aerodrome* of intended landing and at any *destination alternate aerodrome*, exceed the relevant maximum masses at which compliance has been demonstrated with the applicable *aircraft* noise certification, unless otherwise authorised in exceptional circumstances for a certain *aerodrome* or a runway where there is no noise disturbance problem, by the competent authority of the State in which the *aerodrome* is situated.

5.1.6 Take-off

5.1.6.1 The *aeroplane* shall be able, in the event of a critical power-unit failing at any point in the take-off, either to discontinue the take-off and stop within the accelerate-stop distance available [or runway available], or to continue the take-off and clear all obstacles along the flight path by an adequate margin until the *aeroplane* is in a position to comply with 5.1.7.

5.1.6.2 In determining the length of the runway available, account shall be taken of the loss, if any, of runway length due to alignment of the *aeroplane* prior to take-off.

5.1.7 En route — one power-unit inoperative

5.1.7.1 The *aeroplane* shall be able, in the event of the critical engine becoming inoperative at any point along the route or planned diversions therefrom, to continue the flight to an *aerodrome* at which the requirement of 5.1.8 can be met, without flying below the minimum *obstacle clearance altitude* at any point.

5.1.8 Landing

5.1.8.1 The *aeroplane* shall, at the *aerodrome* of intended landing and at any *alternate aerodrome*, after clearing all obstacles in the approach path by a safe margin, be able to land, with assurance that it can come to a stop or, for a seaplane, to a satisfactorily low speed, within the landing distance available. Allowance shall be made for expected variations in the approach and landing techniques, if such allowance has not been made in the scheduling of performance data.

6 AEROPLANE INSTRUMENTS, EQUIPMENT AND FLIGHT DOCUMENTS

6.1 General

- 6.1.1 Where a master minimum equipment list (MMEL) is established for the *aircraft* type, the *operator* of a Singapore *aeroplane* to which this Chapter applies shall include in the *operations manual* a minimum equipment list (MEL) approved by the *Chief Executive* which will enable the *pilot-in-command* to determine whether a flight may be commenced or continued from any intermediate stop should any instrument, equipment or systems become inoperative.

Note. - Appendix E contains guidance on the minimum equipment list.

- 6.1.2 The *operator* of a Singapore *aeroplane* to which this Chapter applies shall provide operations staff and flight crew with an *aircraft* operating manual, for each *aircraft* type operated, containing the normal, abnormal and emergency procedures relating to the operation of the *aircraft*. The manual shall be consistent with the *aircraft flight manual* and checklists to be used. The design of the manual shall observe Human Factors principles.

6.2 Aeroplanes on all flights

- 6.2.1 In addition to the requirements contained in Chapter 2 para 4.2.2, a flight shall be not commenced unless the *aeroplane* is equipped with:

- a) accessible and adequate medical supplies appropriate to the number of passengers the *aeroplane* is authorised to carry;
- b) medical supplies shall comprise one or more first aid kits;
Note. - Guidance on the types, number, location and contents of the medical supplies can be found in Fifth Schedule of the Air Navigation Order.
- c) a safety harness for each flight crew seat. The safety harness for each pilot seat shall incorporate a device which will automatically restrain the occupant's torso in the event of rapid deceleration;

Note. - The safety harness for each pilot seat shall incorporate a device to prevent a suddenly incapacitated pilot from interfering with the flight controls.

Note. - Safety harness includes shoulder straps and a seat belt which may be used independently.

- d) means of ensuring that the following information and instructions are conveyed to passengers:
 - i) when seat belts are to be fastened;
 - ii) when and how oxygen equipment is to be used if the carriage of oxygen is required;

- iii) restrictions on smoking;
- iv) location and use of life jackets or equivalent individual flotation devices where their carriage is required;
- v) location of emergency equipment; and
- vi) location and method of opening emergency exits.

6.2.2 A flight shall not be commenced unless the *aeroplane* carries:

- a) the *operations manual* prescribed in 4.2.2, or those parts of it that pertain to flight operations;
- b) the *flight manual* for the *aeroplane*, or other documents containing the *aeroplane* performance operating limitations and any other information necessary for the operation of the *aeroplane* within the terms of its certificate of airworthiness, unless these data are available in the *operations manual*; and
- c) the checklists to which 4.2.5 refers.

6.2.3 *Aeroplanes* on long-range over-water flights

6.2.3.1 The *operator* of a Singapore *aeroplane* to which this Chapter applies, operating an extended flight over water, shall determine the risks to survival of the occupants of the *aeroplane* in the event of a ditching. The *operator* shall take into account the operating environment and conditions such as, but not limited to, sea state and sea and air temperatures, the distance from land suitable for making an emergency landing, and the availability of search and rescue facilities. Based upon the assessment of these risks, the *operator* shall, in addition to the equipment required in Chapter 2 para 4.4.3, ensure that the *aeroplane* is appropriately equipped with:

- a) life-saving rafts in sufficient numbers to carry all persons on board, stowed so as to facilitate their ready use in emergency, provided with such lifesaving equipment, including means of sustaining life, as is appropriate to the flight to be undertaken; and
- b) equipment for making the distress signals

6.2.3.2 Each life jacket and equivalent individual flotation device, when carried in accordance with Chapter 2 para 4.4.3, shall be equipped with a means of electric illumination for the purpose of facilitating the location of persons, except where the requirement of 2.4.4.3.1 is met by the provision of individual flotation devices other than life jackets.

6.2.4 *Aeroplanes* for which the individual certificate of airworthiness was first issued before 1 January 1990.

6.2.4.1 A flight intended to be operated at flight altitudes at which the atmospheric pressure will be less than 376 hPa, shall not be commenced unless the

aeroplane is equipped with a device to provide positive warning to the flight crew of any dangerous loss of pressurisation.

6.2.4.2 A flight intended to be operated at flight altitudes at which the atmospheric pressure in personnel compartments is less than 700 hPa in personnel compartments shall not be commenced unless the *aeroplane* is equipped with oxygen storage and dispensing apparatus capable of storing and dispensing the oxygen supplies required in 4.3.6.1.

6.2.4.3 A flight intended to be operated at flight altitudes at which the atmospheric pressure is less than 700 hPa but which is provided with means of maintaining pressures greater than 700 hPa shall not be commenced unless the *aeroplane* is provided with oxygen storage and dispensing apparatus capable of storing and dispensing the oxygen supplies required in 4.3.6.2.

6.3 Aeroplanes in icing conditions

6.3.1 *Aeroplanes* shall be equipped with suitable de-icing and/or anti-icing devices when operated in circumstances in which icing conditions are reported to exist or are expected to be encountered.

6.4 Aeroplanes operated in accordance with the instrument flight rules

6.4.1 In addition to the requirements contained in Chapter 2 para 4.7, a flight operated in accordance with the instrument flight rules or when the *aeroplane* cannot be maintained in a desired attitude without reference to one or more flight instruments, shall not be commenced unless the *aeroplane* is equipped with two independent altitude measuring and display systems.

6.4.2 *Aeroplanes* over 5 700 kg —Emergency power supply for electrically operated attitude indicating instruments

6.4.2.1 A flight operated with *aeroplanes* of a maximum certificated take-off mass of over 5 700 kg newly introduced into service after 1 January 1975 shall not be commenced unless the requirements in 6.5.2.2 to 6.5.2.4 are complied with.

6.4.2.2 The *aeroplane* shall be fitted with an emergency power supply, independent of the main electrical generating system, for the purpose of operating and illuminating, for a minimum period of 30 minutes, an attitude indicating instrument (artificial horizon), clearly visible to the *pilot-in-command*. The emergency power supply shall be automatically operative after the total failure of the main electrical generating system and clear indication shall be given on the instrument panel that the attitude indicator(s) is being operated by emergency power.

6.4.2.3 *Aircraft* with advanced cockpit automation systems (glass cockpits) shall have system redundancy that provides the flight crew with attitude, heading, airspeed and altitude indications in case of failure of the primary system or display.

6.4.2.4 Instruments that are used by any one pilot shall be so arranged as to permit the pilot to see their indications readily from his or her station, with the

minimum practicable deviation from the position and line of vision normally assumed when looking forward along the flight path.

6.5 Pressurised aeroplanes when carrying passengers — weather-detecting equipment

6.5.1 A flight operated with pressurised *aeroplanes* carrying passengers shall not be commenced unless the *aeroplane* is equipped with operative weather-detecting equipment capable of detecting thunderstorms whenever such *aeroplanes* are being operated in areas where such conditions may be expected to exist along the route either at *night* or under instrument meteorological conditions.

6.6 Aeroplanes operated above 15 000 m (49 000 ft) — radiation indicator

6.6.1 A flight operated with an *aeroplane* intending to be primarily operated above 15 000 m (49 000 ft) shall not be commenced unless the *aeroplane* carries equipment to measure and indicate continuously the dose rate of total cosmic radiation being received (i.e. the total of ionising and neutron radiation of galactic and solar origin) and the cumulative dose on each flight. The display unit of the equipment shall be readily visible to a *flight crew member*.

6.7 Aeroplanes required to be equipped with ground proximity warning systems (GPWS)

6.7.1 A flight shall not be commenced unless the *aeroplane* is equipped in accordance with Chapter 2 para 4.11.

6.8 Aeroplanes carrying passengers — cabin crew seats

6.8.1 A flight shall not be commenced unless the *aeroplane* complies with the requirements pertaining to cabin crew seats from 6.9.2 to 6.9.3

6.8.2 *Aeroplanes* shall be equipped with a forward or rearward facing seat (within 15 degrees of the longitudinal axis of the *aeroplane*), fitted with a safety harness for the use of each cabin crew member required to satisfy the intent of 12.1 in respect of emergency evacuation.

Note. - *Safety harness includes shoulder straps and a seat belt which may be used independently.*

6.8.3 Cabin crew seats provided in accordance with 6.9.1 shall be located near floor level and other emergency exits as required by the *Chief Executive* for emergency evacuation.

6.9 Aeroplanes required to be equipped with an airborne collision avoidance system (ACAS)

6.9.1 A flight shall not be commenced unless the *aeroplane* satisfies the requirements regarding the equipage of airborne collision avoidance system from 6.10.2 to 6.10.3.

- 6.9.2 All turbine - engined *aeroplanes* of a maximum certificated take-off mass in excess of 15 000 kg, or authorised to carry more than 30 passengers, for which the individual airworthiness certificate is first issued after 24 November 2005, shall be equipped with an airborne collision avoidance system (ACAS II).
- 6.9.3 All turbine - engined *aeroplanes* of a maximum certificated take-off mass in excess of 5,700 kg but not exceeding 15,000kg, or authorised to carry more than 19 passengers, for which the individual airworthiness certificate is first issued after 1 January 2007, shall be equipped with an airborne collision avoidance system (ACAS II).
- 6.10 *Aeroplanes* required to be equipped with a pressure-altitude reporting transponder**
- 6.10.1 A flight shall not be commenced unless the *aeroplane* is equipped with a pressure-altitude reporting transponder which operates in accordance with the relevant provisions of Annex 10 to the Convention on International Civil Aviation, Volume IV.
- 6.11 Microphones**
- 6.11.1 All *flight crew members* required to be on flight deck duty shall communicate through boom or throat microphones below the transition level/altitude.

7 AEROPLANE COMMUNICATION AND NAVIGATION EQUIPMENT

7.1 Communication equipment

7.1.1 In addition to the requirements of Chpt 2, 5.1.1 to 5.1.5, a flight shall not be commenced unless the *aeroplane* is provided with radio communication equipment capable of:

- a) conducting two-way communication for *aerodrome* control purposes;
- b) receiving *meteorological information* at any time during flight; and
- c) conducting two-way communication at any time during flight with at least one aeronautical station and with such other aeronautical stations and on such frequencies as may be prescribed by the appropriate authority.

Note. - *The requirements of 7.1 are considered fulfilled if the ability to conduct the communications specified therein is established during radio propagation conditions which are normal for the route.*

7.2 Installation

7.2.1 A flight shall not be commenced unless the equipment installation on the *aeroplane* is such that the failure of any single unit required for either communications or navigation purposes or both will not result in the failure of another unit required for communications or navigation purposes.

7.3 Electronic navigation data management

7.3.1 An *operator* of a Singapore *aeroplane* to which this Chapter applies shall

- a) not employ electronic navigation data products that have been processed for application in the air and on the ground unless the *Chief Executive* has approved the *operator's* procedures for ensuring that the process applied and the products delivered have met acceptable standards of integrity and that the products are compatible with the intended function of the equipment that will use them. The *Chief Executive* shall ensure that the *operator* continues to monitor both process and products; and
- b) implement procedures that ensure the timely distribution and insertion of current and unaltered electronic navigation data to all *aeroplanes* that require it.

8 AEROPLANE MAINTENANCE

8.1 Operator's maintenance responsibilities

8.1.1 An operator of a Singapore aeroplane to which this Chapter applies shall –

- a) comply with the requirements of chapter 2 para 6.1.
- b) ensure that all *maintenance* personnel receive initial and continuation training acceptable to the *Chief Executive* and appropriate to their assigned tasks and responsibilities. This shall include Human Factors and coordination with other *maintenance* personnel and flight crew.

8.2 Operator's maintenance control manual

8.2. An operator of a Singapore aeroplane to which this Chapter applies shall provide a maintenance control manual, as specified in 11.1, for the use and guidance of *maintenance* and operations personnel.

8.3 Maintenance programme

8.3.1 An operator of a Singapore aeroplane to which this Chapter applies shall provide, for the use and guidance of *maintenance* and operational personnel concerned, a *maintenance programme*, acceptable to the *Chief Executive*, containing the information required by 11.2. The design and application of the operator's *maintenance programme* shall observe human factors principles.

8.3.2 Copies of all amendments to the *maintenance programme* shall be furnished promptly to all organisations or persons to whom the *maintenance programme* has been issued.

8.4 Continuing airworthiness information – Reporting of defects to the aircraft type certificate holder

8.4.1 An operator of a Singapore aeroplane to which this Chapter applies shall report to the *Chief Executive* and the *aircraft* type certificate holder on faults, malfunctions, defects and other occurrences that cause or might cause adverse effects on the continuing airworthiness of the *aircraft*. The written report is to be submitted within 72 hours of the occurrence.

8.5 Maintenance release

8.5.1 A flight shall not be commenced unless the requirements pertaining to *maintenance release* from 8.5.2 to 8.5.3 are complied with for the *aeroplane*.

8.5.2 A *maintenance release* shall be completed and signed, as prescribed by the *Chief Executive*, to certify that the *maintenance* work has been performed in accordance with the *maintenance programme* or other data and procedures acceptable to the *Chief Executive*.

8.5.3 A *maintenance release* shall contain a certification including:

- a) basic details of the *maintenance* performed;
- b) the date such *maintenance* was completed;
- c) the identity of the approved maintenance ; and
- d) the identity of the person or persons signing the release.

9 AEROPLANE FLIGHT CREW

9.1 Composition of the *flight crew*

9.1.1 Designation of *pilot-in-command*

9.1.1.1 For each flight, the *operator* of a Singapore *aeroplane* to which this Chapter applies shall designate a pilot to act as *pilot-in-command*.

9.1.2 Flight engineer

9.1.2.1 When a separate flight engineer's station is incorporated in the design of an *aeroplane*, the *operator* of a Singapore *aeroplane* to which this chapter applies shall include at least one flight engineer especially assigned to that station, unless the duties associated with that station can be satisfactorily performed by another *flight crew member*, holding a flight engineer licence, without interference with regular duties.

9.2 *Flight crew member emergency duties*

9.2.1 The *operator* of a Singapore *aeroplane* to which this Chapter applies shall, for each type of *aeroplane*, assign to all *flight crew members* the necessary functions they are to perform in an emergency or in a situation requiring emergency evacuation. Recurrent training in accomplishing these functions shall be contained in the *operator's* training programme and shall include instruction in the use of all emergency and life-saving equipment required to be carried, and drills in the emergency evacuation of the *aeroplane*.

9.3 *Flight crew member training programmes*

9.3.1 The *operator* of a Singapore *aeroplane* to which this Chapter applies shall establish and maintain a training programme that is designed to ensure that a person who receives training acquires and maintains the competency to perform assigned duties, including skills related to human performance. Ground and flight training programmes shall be established either through internal programmes or through a training services provider, and shall include or make reference to a syllabus for those training programmes in the company *operations manual*. The training programme shall include training to competency for all equipment installed.

9.3.2 *Flight simulators* shall be used to the maximum extent practicable for initial and annual recurrent training.

9.4 Qualifications

9.4.1 *Flight crew member* licensing

9.4.1.1 The *operator* of a Singapore *aeroplane* to which this Chapter applies shall:

- a) ensure that each *flight crew member* assigned to duty holds a valid licence;

- b) ensure that *flight crew members* are properly rated; and
- c) be satisfied that *flight crew members* are competent to carry out assigned duties.

9.4.1.2 The *operator* of a Singapore *aeroplane* to which this Chapter applies which is equipped with an airborne collision avoidance system (ACAS II) shall ensure that each *flight crew member* has been appropriately trained to competency in the use of ACAS II equipment and the avoidance of collisions.

9.4.2 Recent experience — pilot-in-command

9.4.2.1 The *operator* of a Singapore *aeroplane* to which this Chapter applies shall not assign a pilot to act as *pilot-in-command* of an *aeroplane* unless that pilot has made at least three take-offs and landings within the preceding 90 days on the same type of *aeroplane* or in a *flight simulator* approved for the purpose.

9.4.3 Recent experience — co-pilot

9.4.3.1 The *operator* of a Singapore *aeroplane* to which this Chapter applies shall not assign a co-pilot to operate at the flight controls of an *aeroplane* during take-off and landing unless that pilot has made at least three take-offs and landings within the preceding 90 days on the same type of *aeroplane* or in a *flight simulator* approved for the purpose.

9.4.4 Pilot proficiency checks

9.4.4.1 The *operator* of a Singapore *aeroplane* to which this Chapter applies shall ensure that piloting technique and the ability to execute emergency procedures is checked annually in such a way as to demonstrate the pilot's competence. Where the operation may be conducted under the instrument flight rules, an *operator* shall ensure that the pilot's competence to comply with such rules is demonstrated to either a check pilot of the *operator* or a representative of the *Chief Executive*.

10 FLIGHT OPERATIONS OFFICER/FLIGHT DESPATCHER

- 10.1 The *operator* of a Singapore *aeroplane* to which this Chapter applies shall ensure that any person assigned as a flight operations officer/flight despatcher is trained and maintains familiarisation with all features of the operation which are pertinent to their duties, including knowledge and skills related to Human Factors.

Note. - Appendix G contains guidance on the training of Flight Operations Officer / Flight Despatcher

11 MANUALS, LOGS AND RECORDS

11.1 Operator's maintenance control manual

11.1.1 An *operator's* maintenance control manual provided in accordance with 8.2, which may be issued in separate parts, shall as a minimum contain information about:

- a) the means for complying with the procedures required by 8.1.1;
- b) the means of recording the names and duties of the person or persons responsible for the *maintenance* of the *aeroplane*;
- c) the *maintenance programme* required by 8.3.1;
- d) the methods used for the completion and retention of the *operator's maintenance* records required by chpt 3 paragraph 8.5;
- e) the procedures for reporting to the *Chief Executive* and the *aircraft* type certificate holder on *aircraft* defects that might cause adverse effects on the continuing airworthiness of the *aircraft*;
- f) the procedures for implementing action resulting from mandatory continuing airworthiness information;
- g) a system of analysis and continued monitoring of the performance and efficiency of the *maintenance programme*, in order to correct any deficiency in that programme;
- h) the *aircraft* types and models to which the manual applies;
- i) the procedures for ensuring that unserviceabilities affecting airworthiness are recorded and rectified; and
- j) procedures for advising the *Chief Executive* of significant in-service occurrences.

11.2 Maintenance programme

11.2.1 A *maintenance programme* for each *aeroplane* as required by 8.3 shall contain the following information:

- a) *maintenance* tasks and the intervals at which these are to be performed, taking into account the anticipated utilisation of the *aeroplane*;
- b) when applicable, a continuing structural integrity programme;
- c) procedures for changing or deviating from a) and b) above as approved by the *Chief Executive*; and
- d) when applicable and approved by the *Chief Executive*, condition monitoring and reliability programme descriptions for *aircraft* systems, components and powerplants.

11.2.2 *Maintenance* tasks and intervals that have been specified as mandatory in approval of the type design, or approved changes to the *maintenance programme*, shall be identified as such.

11.2.3 The *maintenance programme* shall be based on *maintenance programme* information made available by the State of Design or by the responsible for the type design, and any additional applicable experience.

11.3 *Flight recorder records*

11.3.1 The owner of the *aeroplane*, or in the case where it is leased, the lessee, shall ensure, to the extent possible, in the event the *aeroplane* becomes involved in an *accident* or incident, the preservation of all related *flight recorder* records and, if necessary, the associated *flight recorders*, and their retention in safe custody pending their disposition in accordance with Paragraph 37(5) of the Air Navigation Order.

12 CABIN CREW

12.1 Assignment of emergency duties

12.1.1 The requirement for cabin crew for each type of *aeroplane* shall be determined by the *operator*, based on seating capacity or the number of passengers carried, in order to effect a safe and expeditious evacuation of the *aeroplane*, and the necessary functions to be performed in an emergency or a situation requiring emergency evacuation. The *operator* shall assign these functions for each type of *aeroplane*.

12.2 Cabin crew at emergency evacuation stations

12.2.1 Each cabin crew member assigned to emergency evacuation duties shall occupy a seat provided in accordance with chpt 3 paragraph 6.9 during take-off and landing and whenever the *pilot-in-command* so directs.

12.3 Protection of cabin crew during flight

12.3.1 Each cabin crew member shall be seated with seat belt or, when provided, safety harness fastened during takeoff and landing and whenever the *pilot-in-command* so directs.

12.4 Training

12.4.1 The *operator* of a Singapore *aeroplane* to which this Chapter applies shall

- a) ensure that a training programme is completed by all persons before being assigned as a cabin crew member; and
- b) establish and maintain a cabin crew training programme that is designed to ensure that persons who receive training acquire the competency to perform their assigned duties and includes or makes reference to a syllabus for the training programme in the company *operations manual*. The training programme shall include Human Factors training.

13 SECURITY

13.1 Security programme

13.1.1 The *operator* of a Singapore *aeroplane* to which this Chapter applies shall

- a) establish a written security programme and shall ensure that such a programme meets the national civil aviation security programmes of all States to which it operates;
- b) establish, maintain and conduct approved training programmes which enable the *operator's* personnel to take appropriate action to prevent acts of unlawful interference such as sabotage or unlawful seizure of *aeroplanes* and to minimise the consequences of such events should they occur. The training programme shall include at least the elements identified in Appendix H. Such training programmes shall be periodically reviewed to ensure that it is kept abreast with the latest developments; and
- c) establish and maintain a training programme to acquaint appropriate employees with preventive measures and techniques in relation to passengers, baggage, cargo, mail, equipment, stores and supplies intended for carriage on an *aeroplane* so that they contribute to the prevention of acts of sabotage or other forms of unlawful interference.

Intentionally Left Blank

APPENDIX A [Chpt 2, 4.8.1] LIGHTS TO BE DISPLAYED BY *AEROPLANES*

EFFECTIVE DATE : 15 JULY 2010
REVISION NO : 0 (ISSUE 1)

1 Terminology

When the following terms are used in this Appendix, they have the following meanings:

Angles of coverage.

- a) Angle of coverage A is formed by two intersecting vertical planes making angles of 70 degrees to the right and 70 degrees to the left respectively, looking aft along the longitudinal axis to a vertical plane passing through the longitudinal axis.
- b) Angle of coverage F is formed by two intersecting vertical planes making angles of 110 degrees to the right and 110 degrees to the left respectively, looking forward along the longitudinal axis to a vertical plane passing through the longitudinal axis.
- c) Angle of coverage L is formed by two intersecting vertical planes, one parallel to the longitudinal axis of the *aeroplane*, and the other 110 degrees to the left of the first, when looking forward along the longitudinal axis.
- d) Angle of coverage R is formed by two intersecting vertical planes, one parallel to the longitudinal axis of the *aeroplane*, and the other 110 degrees to the right of the first, when looking forward along the longitudinal axis.

Horizontal plane. The plane containing the longitudinal axis and perpendicular to the plane of symmetry of the *aeroplane*.

Longitudinal axis of the *aeroplane*. A selected axis parallel to the direction of flight at a normal cruising speed, and passing through the centre of gravity of the *aeroplane*.

Making way. An *aeroplane* on the surface of the water is “making way” when it is under way and has a velocity relative to the water.

Under command. An *aeroplane* on the surface of the water is “under command” when it is able to execute manoeuvres as required by the International Regulations for Preventing Collisions at Sea for the purpose of avoiding other vessels.

Under way. An *aeroplane* on the surface of the water is “under way” when it is not aground or moored to the ground or to any fixed object on the land or in the water.

Vertical planes. Planes perpendicular to the horizontal plane.

Visible. Visible on a dark *night* with a clear atmosphere.

2 Navigation lights to be displayed in the air

Note. - The lights specified herein are intended to meet the requirements of Annex 2 to the Convention on International Civil Aviation for navigation lights.

As illustrated in Figure 1, the following unobstructed navigation lights shall be displayed:

- a) a red light projected above and below the horizontal plane through angle of coverage L;
- b) a green light projected above and below the horizontal plane through angle of coverage R;
- c) a white light projected above and below the horizontal plane rearward through angle of coverage A.

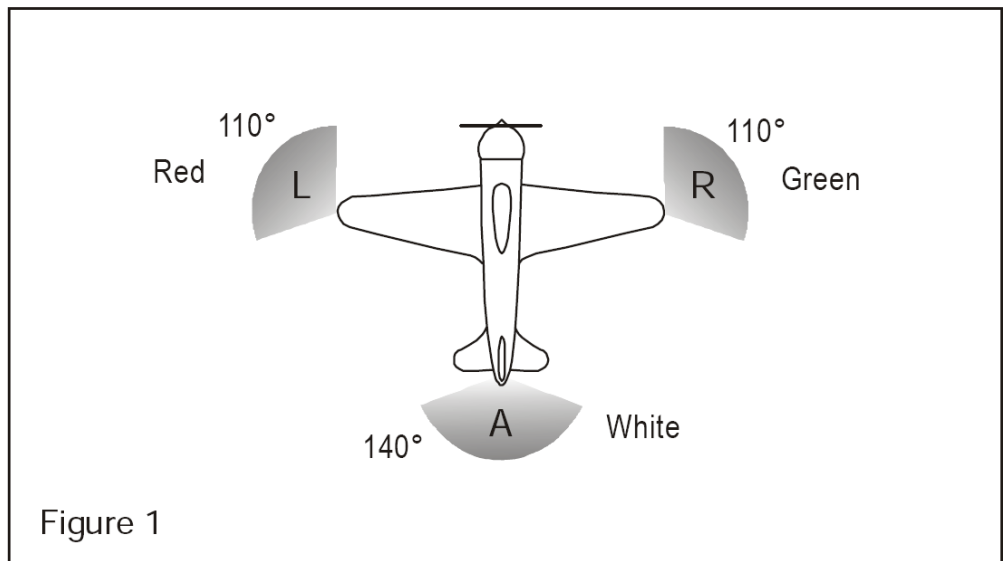

3. Lights to be displayed on the water

3.1 General

Note. - The lights specified herein are intended to meet the requirements for lights to be displayed by aeroplanes on the water.

The International Regulations for Preventing Collisions at Sea require different lights to be displayed in each of the following circumstances:

- a) when under way;
- b) when towing another vessel or *aeroplane*;
- c) when being towed;
- d) when not under command and not making way;
- e) when making way but not under command;
- f) when at anchor;
- g) when aground.

The lights required by *aeroplanes* in each case are described below.

3.2 When under way

As illustrated in Figure 2, the following appearing as steady unobstructed lights:

- a) a red light projected above and below the horizontal plane through angle of coverage L;
- b) a green light projected above and below the horizontal plane through angle of coverage R;
- c) a white light projected above and below the horizontal plane through angle of coverage A; and
- d) a white light projected through angle of coverage F.

The lights described in a), b) and c) should be visible at a distance of at least 3.7km (2 NM). The light described in d) should be visible at a distance of 9.3 km (5 NM) when fitted to an *aeroplane* of 20 m or more in length or visible at a distance of 5.6 km (3 NM) when fitted to an *aeroplane* of less than 20 m in length.

3.3 When towing another vessel or *aeroplane*

As illustrated in Figure 3, the following appearing as steady, unobstructed lights:

- a) the lights described in 3.2;
- b) a second light having the same characteristics as the light described in 3.2 d) and mounted in a vertical line at least 2 m above or below it; and
- c) a yellow light having otherwise the same characteristics as the light described in 3.2 c) and mounted in a vertical line at least 2 m above it.

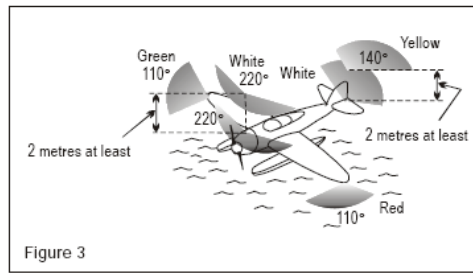
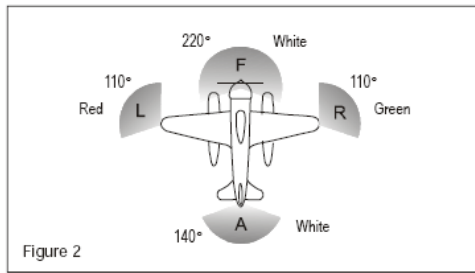

3.4 When being towed

The lights described in 3.2 a), b) and c) appearing as steady, unobstructed lights.

3.5 When not under command and not making way

As illustrated in Figure 4, two steady red lights placed where they can best be seen, one vertically over the other and not less than 1 m apart, and of such a character as to be visible all around the horizon at a distance of at least 3.7 km (2 NM).

3.6 When making way but not under command

As illustrated in Figure 5, the lights described in 3.5 plus the lights described in 3.2 a), b) and c).

Note. - The display of lights prescribed in 3.5 and 3.6 is to be taken by other aircraft as signals that the aeroplane showing them is not under command and cannot therefore get out of the way. They are not signals of aeroplanes in distress and requiring assistance.

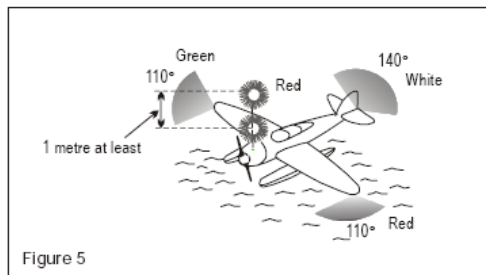
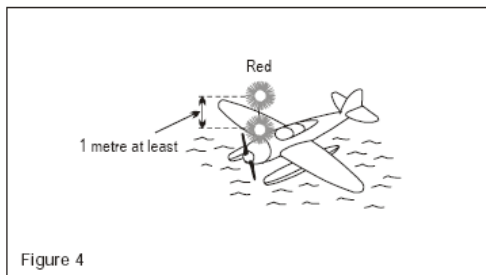

3.7 When at anchor

- a) If less than 50 m in length, where it can best be seen, a steady white light (Figure 6), visible all around the horizon at a distance of at least 3.7 km (2 NM).
- b) If 50 m or more in length, where they can best be seen, a steady white forward light and a steady white rear light (Figure 7) both visible all around the horizon at a distance of at least 5.6 km (3 NM).

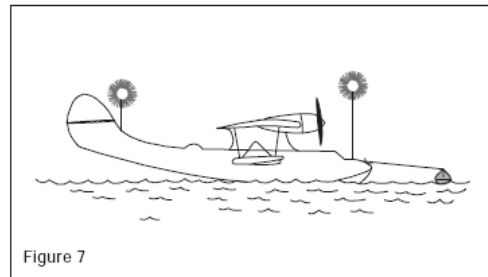
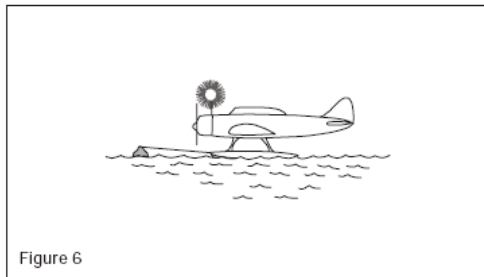

- c) If 50 m or more in span a steady white light on each side (Figures 8 and 9) to indicate the maximum span and visible, so far as practicable, all around the horizon at a distance of at least 1.9 km (1 NM).

3.8 When aground

The lights prescribed in 3.7 and in addition two steady red lights in vertical line, at least 1 m apart so placed as to be visible all around the horizon.

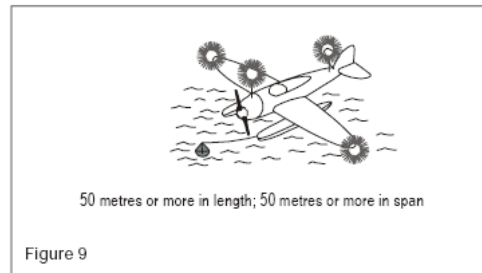
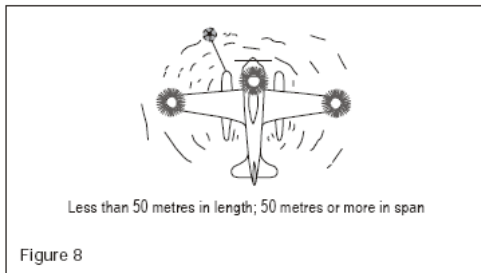

Intentionally Left Blank

APPENDIX B [Chpt 2, 5.2.4(c) and 5.2.5(a)] ALTIMETRY SYSTEM PERFORMANCE REQUIREMENTS FOR OPERATIONS IN RSVM AIRSPACE

EFFECTIVE DATE : 15 JULY 2010

REVISION NO : 0 (ISSUE 1)

- 1 In respect of groups of *aeroplanes* that are nominally of identical design and build with respect to all details that could influence the accuracy of height-keeping performance, the height-keeping performance capability shall be such that the total vertical error (TVE) for the group of *aeroplanes* shall have a mean no greater than 25 in (80 ft) in magnitude and shall have a standard deviation no greater than $28 - 0.0135z$ for $0 < z < 25$ when z is the magnitude of the mean TVE in metres, or $92 - 0.004z$ for $0 < z \leq 80$ where z is in feet. In addition, the components of TVE shall have the following characteristics:
 - a) the mean altimetry system error (ASE) of the group shall not exceed 25 in (80 ft) in magnitude;
 - b) the sum of the absolute value of the mean ASE and of three standard deviations of ASE shall not exceed 75 in (245 ft); and
 - c) the differences between cleared flight level and the indicated pressure altitude actually flown shall be symmetric about a mean of 0 in, with a standard deviation no greater than 13.3 in (43.7 ft), and in addition, the decrease in the frequency of differences with increasing difference magnitude shall be at least exponential.

- 2 In respect of *aeroplanes* for which the characteristics of the airframe and altimetry system fit are unique and so cannot be classified as belonging to a group of *aeroplanes* encompassed by paragraph 1, the height-keeping performance capability shall be such that the components of the TVE of the *aeroplane* have the following characteristics:
 - a) the ASE of the *aeroplane* shall not exceed 60 in (200 ft) in magnitude under all flight conditions; and
 - b) the differences between the cleared flight level and the indicated pressure altitude actually flown shall be symmetric about a mean of 0 m, with a standard deviation no greater than 13.3 m (43.7 ft), and in addition, the decrease in the frequency of differences with increasing difference magnitude shall be at least exponential.

Intentionally Left Blank

APPENDIX C [Chpt 2, 2.3.8.1] CARRIAGE AND USE OF OXYGEN

EFFECTIVE DATE : 15 JULY 2010
REVISION NO : 0 (ISSUE 1)

1 Oxygen supply

- 1.1 A flight to be operated at altitudes at which the atmospheric pressure in personnel compartments will be less than 700 hPa shall not be commenced unless sufficient stored breathing oxygen is carried to supply:
- a) all crew members and at least 10 per cent of the passengers for any period in excess of 30 minutes that the pressure in compartments occupied by them will be between 700 hPa and 620 hPa; and
 - b) all crew members and passengers for any period that the atmospheric pressure in compartments occupied by them will be less than 620 hPa.
- 1.2 A flight to be operated with a pressurised *aeroplane* shall not be commenced unless a sufficient quantity of stored breathing oxygen is carried to supply all crew members and passengers, as is appropriate to the circumstances of the flight being undertaken, in the event of loss of pressurisation, for any period that the atmospheric pressure in any compartment occupied by them would be less than 700 hpa. In addition, when an *aeroplane* is operated at flight altitudes at which the atmospheric pressure is less than 376 hPa, or which, if operated at flight altitudes at which the atmospheric pressure is more than 376 hPa and cannot descend safely within four minutes to a flight altitude at which the atmospheric pressure is equal to 620 hPa, there shall be no less than a 10-minute supply for the occupants of the passenger compartment.

2 Use of oxygen

- 2.1 All *flight crew members*, when engaged in performing duties essential to the safe operation of an *aeroplane* in flight, shall use breathing oxygen continuously whenever the circumstances prevail for which its supply has been indicated to be necessary in 1.1 or 1.2.
- 2.2 All *flight crew members* of pressurised *aeroplanes* operating above an altitude where the atmospheric pressure is less than 376 hPa shall have available at the flight duty station a quick donning type of mask which will readily supply oxygen upon demand.

Note. - Approximate altitudes in the Standard Atmosphere corresponding to the values of absolute pressure used in the text are as follows:

Absolute pressure	Metres	Feet
<i>700 hPa</i>	<i>3 000</i>	<i>10 000</i>
<i>620 hPa</i>	<i>4 000</i>	<i>13 000</i>
<i>376 hPa</i>	<i>7 600</i>	<i>25 000</i>

APPENDIX D [Chpt 3, 4.2.2.1] COMPANY OPERATIONS MANUAL

EFFECTIVE DATE : 18 NOVEMBER 2010

REVISION NO : 1 (ISSUE 1)

The following is the suggested content of a company *operations manual*. It may be issued in separate parts corresponding to specific aspects of an operation. It shall include the instructions and information necessary to enable the personnel concerned to perform their duties safely and shall contain at least the following information:

- a) table of contents;
- b) amendment control page and list of effective pages, unless the entire document is reissued with each amendment and the document has an effective date on it;
- c) duties, responsibilities and succession of management and operating personnel;
- d) *operator* safety management system;
- e) *operational control* system;
- f) MEL procedures (where applicable);
- g) normal flight operations;
- h) SOPs;
- i) weather limitations;
- j) flight and duty time limitations;
- k) emergency operations;
- l) accident/incident considerations;
- m) personnel qualification and training;
- n) record keeping;
- o) a description of the maintenance control system;
- p) security procedures (where applicable);
- q) performance operating limitations;
- r) use/protection of FDR/CVR records (where applicable); and

- s) handling of *dangerous goods*; and
- t) use of *head-up displays (HUD)* /*enhanced vision systems (EVS)*.

APPENDIX E [Chpt 3, 6.1.1]

MINIMUM EQUIPMENT LIST (MEL)

EFFECTIVE DATE : 15 JULY 2010

REVISION NO : 0 (ISSUE 1)

- 1 If deviations from the requirements in the certification of *aircraft* were not permitted, an *aircraft* could not be flown unless all systems and equipment were operable. Experience has proved that some unserviceability can be accepted in the short term when the remaining operative systems and equipment provide for continued safe operations.
- 2 To permit an *aeroplane* to fly with certain acceptable component unserviceability, a minimum equipment list, approved by the *Chief Executive*, is therefore necessary for each *aircraft*, based on the master minimum equipment list established for the *aircraft* type by the organisation responsible for the type design in conjunction with the State of Design.
- 3 The *operator* is required to prepare a minimum equipment list designed to allow the operation of an *aircraft* with certain systems or equipment inoperative provided an acceptable level of safety is maintained.
- 4 The minimum equipment list is not intended to provide for operation of the *aircraft* for an indefinite period with inoperative systems or equipment. The basic purpose of the minimum equipment list is to permit the safe operation of an *aircraft* with inoperative systems or equipment within the framework of a controlled and sound programme of *repairs* and parts replacement.
- 5 *Operators* are to ensure that no flight is commenced with multiple minimum equipment list items inoperative without determining that any interrelationship between inoperative systems or components will not result in an unacceptable degradation in the level of safety and/or undue increase in the flight crew workload.
- 6 The exposure to additional failures during continued operation with inoperative systems or equipment shall also be considered in determining that an acceptable level of safety is being maintained. The minimum equipment list may not deviate from requirements of the *flight manual* limitations section, emergency procedures or other airworthiness requirements of the *Chief Executive*.
- 7 Systems or equipment accepted as inoperative for a flight should be placarded where appropriate and all such items should be noted in the *aircraft* technical log to inform the flight crew and *maintenance* personnel of the inoperative system or equipment.
- 8 For a particular system or item of equipment to be accepted as inoperative, it may be necessary to establish a *maintenance* procedure, for completion prior

- 9 to flight, to deactivate or isolate the system or equipment. It may similarly be necessary to prepare an appropriate flight crew operating procedure.
- 10 The responsibilities of the *pilot-in-command* in accepting an *aeroplane* for operation with deficiencies in accordance with a minimum equipment list are specified in Chapter 2, paragraph 2.3.1.
- 11 Guidelines on the preparation of the MEL can be found in SAR Chapter 4.10.

APPENDIX F [Chpt 3, 4.4.3.1] NOISE ABATEMENT PROCEDURES

EFFECTIVE DATE : 15 JULY 2010
REVISION NO : 0 (ISSUE 1)

- 1 Noise abatement regulations frequently require special handling techniques and routings after take-off. The *flight manuals* of the more recently certificated *aeroplanes* contain performance data related to noise abatement procedures. Details of the procedures for each airfield or runway used by the *operator*, for which noise abatement regulations exist, should be provided in the *operations manual*. Instructions to ignore noise abatement procedures in emergency situations should also be included.
- 2 Where, in exceptional circumstances, it may be appropriate in the course of noise abatement procedures to start a turn at less than 500 ft agl, pilots should be given suitable instructions about restricting the angle of bank. Pilots should also be instructed not to reduce thrust below 500 ft agl. Above 500 ft agl thrust should be reduced in accordance with the *aircraft* manufacturers' instructions. In the absence of such guidance, thrust should not be reduced to an extent that would result in a gross gradient of climb of less than 4%.

Intentionally Left Blank

APPENDIX G [Chpt 3, 10.1] FLIGHT OPERATIONS OFFICER/FLIGHT DESPATCHER (FOO/FD)

EFFECTIVE DATE : 18 NOVEMBER 2010

REVISION NO : 1 (ISSUE 1)

1 INTRODUCTION

- 1.1 *Operators* are required to demonstrate an adequate organisation method of control and supervision of flight operation. A flight operations officer/flight despatcher is normally employed to provide supervision of flight and to act as a close link between *aircraft* in flight and the ground services, and also between the aircrew and the *operators'* ground staff.
- 1.2 Singapore does not issue flight operations officer/flight despatcher licences. Flight operations officers/Flight despatcher applicants must meet the criteria established in this attachment.

2 BASIC REQUIREMENTS

2.1 Age

- 2.1.1 The flight operations officer/flight despatcher shall not be less than 21 years of age.

2.2 Knowledge

- 2.2.1 The flight operations officer/flight despatcher shall be able to demonstrate an appropriate level of knowledge in at least the subjects specified in paragraph 6. Such demonstration of knowledge shall be by means of an examination equivalent to that required to be undertaken by a flight operations officer/flight despatcher who has completed a course of training in accordance with paragraph 2.3.1 (c).

2.3 Experience

- 2.3.1 The flight operations officer/flight despatcher shall have gained at least the following experience:
- a) a total of 2 years of service in any one or in any combination of the capacities specified below, provided that in any combination of experience the period serviced in any capacity shall be at least one year:
 - i) a *flight crew member* in air transportation; or
 - ii) a meteorologist in an organisation dispatching *aircraft* in air transportation; or

- iii) an air traffic controller; or a technical supervisor of flight operations officers or air transportation flight operations systems; or
- b) at least one year as an assistant in the dispatching of air transport *aircraft*; or
- c) have satisfactorily completed a course of approved training.

2.3.2 The flight operations officer/flight dispatcher shall have served under the supervision of a flight dispatcher for at least 90 working days within the six months immediately preceding the application.

2.4 Skill

2.4.1 The flight operations officer/flight dispatcher shall have demonstrated the ability to:

- a) make an accurate and operationally acceptable weather analysis from a series of daily weather maps and weather reports; provide an operationally valid briefing on weather conditions prevailing in the general neighbourhood of a specific air route; forecast weather trends pertinent to air transportation with particular reference to destination and alternates;
- b) determine the optimum *flight plan* for a given segment, and create accurate manual and/or computer generated *flight plans*; and
- c) provide operating supervision and all other assistance to a flight in actual or simulated adverse weather conditions, as appropriate to the duties of a flight operations officer/flight dispatcher.

3 ADDITIONAL OPERATOR-SPECIFIC REQUIREMENTS

3.1 In addition to the basic requirements given in paragraph 2 above, the *operator* shall not assign a flight operations officer/flight dispatcher to duty unless that person has:

- a) satisfactorily completed a training course specific to the *operator* that addresses all the components of the *operator's* approved method of control and supervision of flight operations;
- b) (made, within the preceding 12 months, at least one qualification flight in the flight crew compartment of an *aircraft* over any area for which that individual is authorised to exercise flight supervision.

Note. - For the purpose of the qualification flight, the flight operations officer/flight dispatcher must be able to monitor the flight crew intercommunication system and radio communications, and be able to observe the actions of the flight crew from the crew reporting time until the completion of the crew's post-flight duties.

- c) demonstrated to the *operator* a knowledge of:
 - i) the contents of the *operations manual*;
 - ii) the radio equipment in the *aircraft* used; and
 - iii) the navigation equipment in the *aircraft* used;
- d) demonstrated to the *operator* a knowledge of the following details concerning operations for which the officer is responsible and areas in which that individual is authorised to exercise flight supervision:
 - i) seasonal meteorological conditions and the sources of *meteorological information*;
 - ii) the effects of meteorological conditions on radio reception in the *aircraft* used;
 - iii) the peculiarities and limitations of each navigation system which is used by the operation; and
 - iv) the *aircraft* loading instructions;
- e) demonstrated to the *operator* knowledge and skills related to human performance relevant to dispatch duties; and
- f) demonstrated to the *operator* the ability to perform the duties specified in his workscope.

4 AUTHORISATION BY THE OPERATOR

- 4.1 The *operator* shall establish a system to ensure that each flight operations officer/flight dispatcher assigned to duty continues to meet all the requirements in this Attachment.
- 4.2 The *operator* shall ensure that appropriate action is taken to suspend, vary or revoke the authorisation of a flight operations officer/flight dispatcher in the event that he or she fails to continue to meet the requirements of this Attachment.

5 MAINTAINING CURRENCY

- 5.1 To maintain currency, a flight operations officer/flight dispatcher must dispatch at least one flight every 90 consecutive days. A flight operations officer/flight dispatcher who fails to do so shall be required to dispatch at least one flight under the supervision of another flight operations officer/flight dispatcher prior to resuming duties.
- 5.2 A flight operations officer/flight dispatcher who has not dispatched at least one flight in the preceding 12 months shall be required to attend refresher

training and dispatch at least one flight under the supervision of another flight operations officer/flight dispatcher prior to resuming duties.

- 5.3 Every flight operations officer/flight dispatcher shall undergo a recurrent training programme approved by the *Chief Executive* and pass a proficiency test conducted by the *operator* once every 24 months.

6 TRAINING SYLLABUS

- 6.1 An *operator* intending to develop a course of training to qualify flight operations officers/flight dispatchers in accordance with paragraph 2.3.1(c) shall submit the basic training syllabi for initial qualification training to the *Chief Executive* for approval. The syllabi shall be part of the *Operator's operations manual* and training manual. The training shall cover the contents specified below and include an examination at the end of the course.

FLIGHT OPERATION OFFICER/FLIGHT DISPATCHER

1 PHASE ONE – BASIC KNOWLEDGE

1.1 Civil air law and regulations

Certification of *operators*.
The Convention on International Civil Aviation (The Chicago Convention).
International air transport issues addressed by the Chicago Convention.
The International Civil Aviation Organisation (ICAO).
Responsibility for *aircraft* airworthiness.
Regulatory provisions of the *flight manual*.
The *aircraft* minimum equipment list (MEL).
The *operations manual*.

1.2 Aviation Indoctrination

Regulatory.
Aviation terminology and terms of reference.
Theory of flight and flight operations.
Aircraft propulsion systems.
Aircraft systems.

1.3 Aircraft mass (weight) and performance

Basic principles for flight safety.
Basic mass (weight) and speed limitations.
Take-off runway requirements.
Climb performance requirements.
Landing runway requirements.
Buffet boundary speed limitations.

1.4 Navigation

Position and distance; time.

True, magnetic and compass direction; gyro heading reference and grid direction.

Introduction to chart projection: the Mercator projection; great circles on Mercator charts; other cylindrical projections; Lambert conformal conic projections; the polar stereographic projection.

ICAO chart requirements.

Charts used by a typical *operator*.

Measurement of airspeed; track and ground speed.

Use of slide-rules, computers and scientific calculators.

Measurement of *aircraft* altitude.

Point of no return; critical point; general determination of *aircraft* position.

Introduction to radio navigation; ground-based radar and direction-finding stations; relative bearings; VOR/DME-type radio navigation; instrument landing systems.

Navigation procedures.

ICAO CNS/ATM systems (an overview)

1.5 Air traffic management

Introduction to air traffic management

Controlled airspace

Flight rules

ATC clearance; ATC requirements for *flight plans*; *aircraft* reports.

Flight information service (FIS).

Alerting service and search and rescue.

Communications services (mobile, fixed).

Aeronautical information service (AIS).

Aerodrome and airport services.

1.6 Meteorology

Atmosphere; atmospheric temperature and humidity.

Atmospheric pressure; pressure-wind relationships.

Winds near the Earth's surface; wind in the free atmosphere; turbulence.

Vertical motion in the atmosphere; formation of clouds and precipitation.

Thunderstorms; *aircraft* icing.

Visibility and RVR; volcanic ash.

Surface observations; upper-air observations; station model.

Air masses and fronts; frontal depressions.

Weather at fronts and other parts of the frontal depression; other types of pressure systems.

General climatology; weather in the tropics.

Aeronautical meteorological reports; analysis of surface and upper-air charts.

Prognostic charts; aeronautical forecasts.

Meteorological service for international air navigation.

Field trip to local meteorological office.

1.7 Mass (weight) and balance control

Introduction to mass and balance.

Load planning.

Calculation of payload and loadsheet preparation.

Aircraft balance and longitudinal stability.

Moments and balance.

The structural aspects of *aircraft* loading.
Dangerous goods and other special cargo.
Issuing loading instructions.

1.8 Transport of *dangerous goods* by air

Introduction.
Dangerous goods, emergency and abnormal situations.
Source documents.
Emergency procedures.

1.9 Flight planning

Introduction to flight planning.
Turbine-powered *aircraft* cruise control methods.
Flight planning charts and tables for turbine-powered *aircraft*.
Calculation of *flight time* and minimum fuel for turbine-powered *aircraft*.
Route selection.
Flight planning situations.
Reclearance.
The flight phases.
Documents to be carried on flights.
Flight planning exercises.
Threats and hijacking.
ETOPS.

1.10 Flight monitoring

Position of *aircraft*.
Effects of ATC reroutes.
Flight equipment failures.
En-route weather changes.
Emergency situations.
Flight monitoring resources.
Position reports.
Ground resource availability.

1.11 Communications – Radio

International aeronautical telecommunications service.
Elementary radio theory.
Aeronautical fixed service.
Aeronautical mobile service.
Radio navigation service.
Automated aeronautical service.

1.12 Human Factors

The meaning of Human Factors.
Dispatch resource management (DRM).
Awareness.

Practice and feedback.
Reinforcement.

1.13 Security (emergencies and abnormal situations)

Familiarity.
Security measures taken by airlines.
Procedures for handling threats, bomb scares, etc.
Emergency due to *dangerous goods*.
Hijacking.
Personal security for the FOO/FD.

2 PHASE TWO – APPLIED PRACTICAL TRAINING

2.1 Applied practical training

Applied practical flight operations.
Simulator LOFT observation and synthetic flight training.
Flight dispatch practices (on-the-job training)
Route familiarisation.

Intentionally Left Blank

APPENDIX H [Chpt 3, 13.1.1b] AVIATION SECURITY TRAINING SYLLABUS – ALL CREW

EFFECTIVE DATE : 15 JULY 2010
REVISION NO : 0 (ISSUE 1)

RECOMMENDED AVIATION SECURITY TRAINING SYLLABUS - ALL CREW

The security training programme established by the *operator* shall include at least the following elements:

- a) Determination of the seriousness of any occurrence
- b) Crew communication and coordination
- c) Appropriate self-defence responses
- d) Use of non-lethal protective devices assigned to crew members whose use is authorised by the *Chief Executive*
- e) Potentially disruptive passengers
- f) Understanding of behaviour of terrorists so as to facilitate the ability of crew members to cope with hijacker behaviour and passenger responses
- g) Live situational training exercises regarding various threat conditions
- h) Flight deck procedures to protect the *aeroplane*
- i) *Aeroplane* search procedures and guidance on least-risk bomb locations where practicable.
- j) Recognition of firearms, explosives and incendiary devices and their components.
- k) Discreet communication to flight crew by cabin crew in the event of suspicious activity or security breaches in the passenger cabin.
- l) Procedures in relation to the flight crew compartment access and exit.
- m) Procedures in relation to a bomb threat or warning, when the *aircraft* is on the ground or in flight.

REFRESHER TRAINING

- a) Current threat assessment.
- b) Review of recent incidents: lessons to be learned.
- c) Government advice.
- d) Reminders of company emergency procedures, manual amendments, etc.
- e) Update of initial training course as appropriate.