



Singapore General Aviation Requirements - Helicopters

Publication of the
Civil Aviation Authority of Singapore
Singapore Changi Airport
P.O.Box 1, Singapore 918141

*Copies of this document may be obtained from
the CAAS website at www.caas.gov.sg*

Intentionally Left Blank

LIST OF EFFECTIVE PAGES

EFFECTIVE DATE : 11 JANUARY 2017

REVISION NO : 3 (ISSUE 1)

| Page No. | Revision No. | Date | Page No. | Revision No. | Date |
|----------|--------------|-------------|----------|--------------|-------------|
| ROR-1 | 3 | 11 Jan 2017 | 2-8 | 3 | 11 Jan 2017 |
| ROR-2 | 3 | 11 Jan 2017 | 2-9 | 3 | 11 Jan 2017 |
| | | | 2-10 | 3 | 11 Jan 2017 |
| LEP-1 | 3 | 11 Jan 2017 | 2-11 | 3 | 11 Jan 2017 |
| LEP-2 | 3 | 11 Jan 2017 | 2-12 | 3 | 11 Jan 2017 |
| | | | 2-13 | 3 | 11 Jan 2017 |
| TOC-1 | 1 | 18 Nov 2010 | 2-14 | 3 | 11 Jan 2017 |
| TOC-2 | 1 | 18 Nov 2010 | 2-15 | 3 | 11 Jan 2017 |
| TOC-3 | 1 | 18 Nov 2010 | 2-16 | 3 | 11 Jan 2017 |
| TOC-4 | 1 | 18 Nov 2010 | 2-17 | 3 | 11 Jan 2017 |
| | | | 2-18 | 3 | 11 Jan 2017 |
| INTRO-1 | 0 | 30 Jul 2010 | 2-19 | 3 | 11 Jan 2017 |
| INTRO-2 | 0 | 30 Jul 2010 | 2-20 | 3 | 11 Jan 2017 |
| | | | 2-21 | 3 | 11 Jan 2017 |
| 1-1 | 3 | 11 Jan 2017 | 2-22 | 3 | 11 Jan 2017 |
| 1-2 | 3 | 11 Jan 2017 | 2-23 | 3 | 11 Jan 2017 |
| 1-3 | 3 | 11 Jan 2017 | 2-24 | 3 | 11 Jan 2017 |
| 1-4 | 3 | 11 Jan 2017 | 2-25 | 3 | 11 Jan 2017 |
| 1-5 | 3 | 11 Jan 2017 | 2-26 | 3 | 11 Jan 2017 |
| 1-6 | 3 | 11 Jan 2017 | | | |
| 1-7 | 3 | 11 Jan 2017 | A-1 | 0 | 30 Jul 2010 |
| 1-8 | 3 | 11 Jan 2017 | A-2 | 0 | 30 Jul 2010 |
| 1-9 | 3 | 11 Jan 2017 | A-3 | 0 | 30 Jul 2010 |
| 1-10 | 3 | 11 Jan 2017 | A-4 | 0 | 30 Jul 2010 |
| 1-11 | 3 | 11 Jan 2017 | A-5 | 0 | 30 Jul 2010 |
| 1-12 | 3 | 11 Jan 2017 | A-6 | 0 | 30 Jul 2010 |
| | | | A-7 | 0 | 30 Jul 2010 |
| 2-1 | 3 | 11 Jan 2017 | A-8 | 0 | 30 Jul 2010 |
| 2-2 | 3 | 11 Jan 2017 | A-9 | 0 | 30 Jul 2010 |
| 2-3 | 3 | 11 Jan 2017 | A-10 | 0 | 30 Jul 2010 |
| 2-4 | 3 | 11 Jan 2017 | A-11 | 0 | 30 Jul 2010 |
| 2-5 | 3 | 11 Jan 2017 | A-12 | 0 | 30 Jul 2010 |
| 2-6 | 3 | 11 Jan 2017 | A-13 | 0 | 30 Jul 2010 |
| 2-7 | 3 | 11 Jan 2017 | A-14 | 0 | 30 Jul 2010 |

| Page No. | Revision No. | Date |
|-----------------|---------------------|-------------|
| A-15 | 0 | 30 Jul 2010 |
| A-16 | 0 | 30 Jul 2010 |
| A-17 | 0 | 30 Jul 2010 |
| A-18 | 0 | 30 Jul 2010 |
| | | |
| B-1 | 0 | 30 Jul 2010 |
| B-2 | 0 | 30 Jul 2010 |
| | | |
| C-1 | 0 | 30 Jul 2010 |
| C-2 | 0 | 30 Jul 2010 |
| | | |
| D-1 | 0 | 30 Jul 2010 |
| D-2 | 0 | 30 Jul 2010 |

TABLE OF CONTENTS

EFFECTIVE DATE : 18 NOVEMBER 2010

REVISION NO : 1 (ISSUE 1)

Table of Contents
Record of Revision
List of Effective Pages
Table of Contents
Introduction

Chapter 1

- 1 Definitions
- 2 Applicability

Chapter 2 – General Aviation- Helicopter Operations

- 1 General
 - 1.1 Compliance with laws, regulations and procedures
 - 1.2 *Dangerous goods*
 - 1.3 Prohibition of use of *psychoactive substances*
 - 1.4 Reporting of *accidents, incidents* and occurrences
- 2 Flight Operations
 - 2.1 Adequacy of operating facilities
 - 2.2 *Heliport Operating Minima*
 - 2.3 Briefings
 - 2.4 *Helicopter* Airworthiness and safety precautions
 - 2.5 Weather reports and Forecasts
 - 2.6 Limitations imposed by weather conditions
 - 2.7 *Alternate Heliports*
 - 2.8 Fuel and Oil supply
 - 2.9 Oxygen supply
 - 2.10 Use of oxygen
 - 2.11 In-flight emergency instruction
 - 2.12 Weather reporting by pilots
 - 2.13 Hazardous flight conditions
 - 2.14 Fitness of *flight crew members*
 - 2.15 *Flight crew members* at duty station
 - 2.16 Instrument flight procedures
 - 2.17 Instruction - general
 - 2.18 Refuelling with passenger on board or rotors turning
 - 2.19 Over-water flights

| | |
|------|------------------------------------------------------------------------------------------------------------|
| 3 | GA <i>Helicopter</i> Performance Operating Limitations |
| 3.1 | General |
| 3.2 | Mass Limitations |
| 3.3 | Obstacle data |
| 4 | GA <i>Helicopter</i> Instruments, Equipment and Flight Documents General |
| 4.1 | <i>Helicopters</i> on all flight |
| 4.2 | Instruments and equipment for flights operated under VFR and IFR – by day and <i>night</i> |
| 4.3 | <i>All Helicopters</i> on flights over water |
| 4.4 | <i>Helicopters</i> on flights over designated areas |
| 4.5 | <i>Helicopters</i> on high altitude flights |
| 4.6 | <i>All helicopters</i> required to comply with the noise certification standards |
| 4.7 | <i>Flight Recorders</i> |
| 4.8 | <i>Emergency Locator Transmitter (ELT)</i> |
| 4.9 | <i>Helicopters</i> to be equipped with a pressure-altitude reporting transponder |
| 4.10 | Microphones |
| 4.11 | <i>Helicopters</i> carrying passengers |
| 4.12 | <i>Helicopters</i> equipped with <i>head-up displays (HUD)</i> and/or <i>enhanced vision systems (EVS)</i> |
| 5 | GA <i>Helicopter</i> Communication and Navigation Equipment |
| 5.1 | Communication equipment |
| 5.2 | Navigation equipment |
| 6 | GA <i>Helicopter Maintenance</i> |
| 6.1 | Owner's <i>maintenance</i> responsibilities |
| 6.2 | <i>Maintenance</i> records |
| 6.3 | Continuing airworthiness information |
| 6.4 | Modifications and <i>repairs</i> |
| 6.5 | <i>Maintenance release</i> |
| 7 | GA <i>Helicopter Flight Crew</i> |
| 7.1 | Qualifications |
| 7.2 | Composition of the <i>flight crew</i> |
| 8 | Manuals, Logs and Records |
| 8.1 | <i>Flight manual</i> |
| 8.2 | Journey log/ Technical log book |
| 8.3 | Records of emergency and survival equipment carried |
| 9 | Security |
| 9.1 | Security of <i>aircraft</i> |
| 9.2 | Reporting <i>acts of unlawful interference</i> |

Appendix

Appendix A – *Helicopters’ Performance and Operating Limitations* [Ref: Para 3.2.2]

Appendix B – *Carriage and Use of Oxygen* [Chpt 2.10, Note 1]

Appendix C – *Operations Manual* [Ref: Para 3.1.1]

Appendix D – *Minimum Equipment List (MEL)* [Ref: 4.1.1]

Intentionally Left Blank

INTRODUCTION

EFFECTIVE DATE : 30 JULY 2010

REVISION NO : 0 (ISSUE 1)

- 1 The Singapore General Aviation Requirements (SGAR) - *Helicopters* is issued by the *Chief Executive* pursuant to paragraph 50A(2) of the Air Navigation Order and contains the requirements for *General Aviation operations*. The owner, *operator* and *pilot-in-command* of a *Singapore helicopter* involved in any *General Aviation operation* shall comply with the requirements of SGAR - *Helicopters* and all other applicable requirements issued by the *Chief Executive*.

- 2 This SGAR - *Helicopters* contains the following:
 - a) Chapter 1, Paragraph 1 - Glossary of definitions used in the SGAR - *Helicopters* (All terms that are defined in this chapter appears in *italics* in the text).
 - b) Chapter 1, Paragraph 2 - Applicability and responsibility for compliance with SGAR - *Helicopters*.
 - c) Chapter 2 - Requirements for *General Aviation operations* operated with *Singapore Helicopters*.

Intentionally Left Blank

CHAPTER 1

EFFECTIVE DATE : 11 JANUARY 2017

REVISION NO : 3 (ISSUE 1)

1 DEFINITIONS

1.1 For the purpose of this SGAR - Helicopters, the following definitions shall apply:

'Accident' means an occurrence associated with the operation of an *aircraft* which takes place between the time any person boards the *aircraft* with the intention of flight until such time as all such persons have disembarked, in which:

- a) a person is fatally or seriously injured as a result of:
 - being in the *aircraft*, or
 - direct contact with any part of the *aircraft*, including parts which have become detached from the *aircraft*, or
 - direct exposure to jet blast, except when the injuries are from natural causes, self inflicted or inflicted by other persons, or when the injuries are to stowaways hiding outside the areas normally available to the passengers and crew; or
- b) the *aircraft* sustains damage or structural failure which:
 - adversely affects the structural strength, performance or flight characteristics of the *aircraft*, and
 - would normally require major *repair* or replacement of the affected component, *except* for engine failure or damage, when the damage is limited to the engine, its cowlings or accessories; or for damage limited to propellers, wing tips, antennas, tires, brakes, fairings, small dents or puncture holes in the *aircraft* skin; or
- c) the *aircraft* is missing or is completely inaccessible.

'Acts of unlawful interference' means acts or attempted acts such as to jeopardise the safety of civil aviation and air transport, i.e.

- a) unlawful seizure of *aircraft* in flight,
- b) unlawful seizure of *aircraft* on the ground,
- c) hostage-taking on board an *aircraft* or on *aerodromes*,
- d) forcible intrusion on board an *aircraft*, at an airport or on the premises of an aeronautical facility,
- e) introduction on board an *aircraft* or at an airport of a weapon or hazardous device or material intended for criminal purposes,
- f) communication of false information as to jeopardise the safety of an *aircraft* in flight or on the ground, of passengers, crew, ground personnel or the general public, at an airport or on the premises of a civil aviation facility.

'Aerial work' means an *aircraft* operation in which an *aircraft* is used for specialised services such as agriculture, construction, photography, surveying, observation and patrol, search and rescue, aerial advertisement, etc.

‘Aircraft’ means any machine that can derive support in the atmosphere from the reactions of the air other than the reactions of the air against the earth’s surface.

‘Aircraft operating manual’ means a manual, acceptable to the *Chief Executive*, containing normal, abnormal and emergency procedures, checklists, limitations, performance information, details of the *aircraft* systems and other material relevant to the operation of the *aircraft*.

Note - The aircraft operating manual is part of the operations manual.

‘Alternate heliport’ means a *heliport* to which a *helicopter* may proceed when it becomes either impossible or inadvisable to proceed to, or to land at, the *heliport* of intended landing and which meets all of the following requirements:

- (a) the necessary services and facilities are available;
- (b) the aircraft performance requirements can be met;
- (c) the heliport is operational at the expected time of use.

Alternate heliports include the following:

- a) **‘Take-off alternate’** means an *alternate heliport* at which a *helicopter* would be able to land if landing becomes necessary shortly after takeoff and it is not possible to use the *heliport* of departure.
- b) **‘En-route alternate’** means an *alternate heliport* at which a *helicopter* would be able to land in the event that a diversion becomes necessary while en route.
- c) **‘Destination alternate’** means an *alternate heliport* to which a *helicopter* would be able to land in the event that it becomes either impossible or inadvisable to land at the *heliport* of intended landing.

Note - The heliport from which a flight departs may be an en-route or a destination alternate heliport for that flight.

‘Approach and landing phase — helicopters’ means that part of the flight from 300 m (1 000 ft) above the elevation of the *FATO*, if the flight is planned to exceed this height, or from the commencement of the descent in the other cases, to landing or to the balked landing point.

‘Cabin crew member’ means a *crew member* who performs, in the interest of safety of passengers, duties assigned by the *operator* or the *pilot-in-command* of the *aircraft*, but who shall not act as a *flight crew member*.

‘Chief Executive’ means the *Chief Executive* of the Authority appointed under section 11 of the Civil Aviation Authority of Singapore Act 2009, and includes any person authorised by him to act on his behalf and any person acting in that capacity.

‘Configuration deviation list (CDL)’ means a list established by the organisation responsible for the type design with the approval of the State of Design which identifies any external parts of an *aircraft* type which may be missing at the commencement of a flight, and which contains, where necessary, any information on associated operating limitations and performance correction.

‘Congested area’ means in relation to a city, town or settlement, any area which is substantially used for residential, commercial or recreational purposes.

‘Congested hostile environment’ means a *hostile environment* within a *congested area*.

‘Continuing airworthiness’ means the set of processes by which all *aircraft* comply with the applicable airworthiness requirements and remain in a condition for safe operation throughout their operating life.

‘Continuous descent final approach (CDFA)’ means a technique, consistent with stabilised approach procedures, for flying the *final approach segment* of a non-precision *instrument approach procedure* as a continuous descent, without level-off, from an altitude/height at or above the final approach fix altitude/height to a point approximately 15m(50 ft) above the landing runway threshold or the point where the flare manoeuvre should begin for the type of aircraft flown.

‘Crew member’ means a person assigned by an *operator* to duty on an *aircraft* during a *flight duty period*.

‘Dangerous goods’ means articles or substances which are capable of posing a risk to health, safety, property or the environment and which are shown in the list of *dangerous goods* in the Technical Instructions or which are classified according to those Instructions.

‘Decision altitude (DA) or decision height (DH)’, in relation to the operation of an helicopter at a heliport, means a specified altitude a *3D instrument approach operation* at which the pilot-in-command must initiate a missed approach if the visual reference to continue the approach has not been established.

Note 1 - Decision altitude (DA) is referenced to mean sea level and decision height (DH) is referenced to the threshold elevation.

Note 2 - The required visual reference means that section of the visual aids or of the approach area which should have been in view for sufficient time for the pilot to have made an assessment of the aircraft position and rate of change of position, in relation to the desired flight path. In Category III operations with a decision height the required visual reference is that specified for the particular procedure and operation.

Note 3 - For convenience where both expressions are used they may be written in the form “decision altitude/height” and abbreviated “DA/H”.

‘Defined point after take-off (DPATO)’ means the point, within the *take-off and initial climb phase*, before which the *helicopter’s* ability to continue the flight safely, with one engine inoperative, is not assured and a forced landing may be required.

Note - Defined points apply to helicopters operating in performance Class 2 only.

‘Defined point before landing (DPBL)’ means the point, within the approach and landing phase, after which the *helicopter’s* ability to continue the flight safely, with one engine inoperative, is not assured and a forced landing may be required.

Note - Defined points apply to helicopters operating in performance Class 2 only.

‘Elevated heliport’ means a *heliport* located on a raised structure on land.

‘Emergency locator transmitter (ELT)’ means a generic term describing equipment which broadcast distinctive signals on designated frequencies and, depending on application, may be automatically activated by impact or be manually activated. An *ELT* may be any of the following:

- a) *Automatic fixed ELT (ELT (AF)).* An automatically activated *ELT* which is permanently attached to an *aircraft*.
- b) *Automatic portable ELT (ELT (AP)).* An automatically activated *ELT* which is rigidly attached to an *aircraft* but readily removable from the *aircraft*.
- c) *Automatic deployable ELT (ELT (AD)).* An *ELT* which is rigidly attached to an *aircraft* and which is automatically deployed and activated by impact, and, in some cases, also by hydrostatic sensors. Manual deployment is also provided.
- d) *Survival ELT (ELT(S)).* An *ELT* which is removable from an *aircraft*, stowed so as to facilitate its ready use in an emergency, and manually activated by survivors.

‘En-route phase’ means the part of the flight from the end of the *take-off and initial climb phase* to the commencement of the approach and landing phase.

Note - Where adequate obstacle clearance cannot be guaranteed visually, flights must be planned to ensure that obstacles can be cleared by an appropriate margin. In the event of failure of the critical power-unit, operators may need to adopt alternative procedures.

‘Enhanced vision system (EVS)’ means a system to display electronic real-time images of the external scene achieved through the use of image sensors.

‘Final approach and take-off area (FATO)’ means a defined area over which the final phase of the approach manoeuvre to hover or landing is completed and from which the take-off manoeuvre is commenced. Where the *FATO* is to be used by *helicopters* operating in *performance Class 1*, the defined area includes the rejected take-off area available.

‘Final approach segment (FAS)’ means that segment of an *instrument approach procedure* in which alignment and descent for landing are accomplished.

‘Flight crew member’ means a licensed *crew member* charged with duties essential to the operation of an *aircraft* during a *flight duty period*.

‘Flight duty period’ means the total time from the moment a *flight crew member* commences duty, immediately subsequent to a *rest period* and prior to making a flight or a *series of flights*, to the moment the *flight crew member* is relieved of all duties having completed such flight or *series of flights*.

‘Flight manual’ means a manual, associated with the certificate of airworthiness, containing limitations within which the *aircraft* is to be considered airworthy, and instructions and information necessary to the *flight crew members* for the safe operation of the *aircraft*.

‘Flight operations officer/flight dispatcher’ means a suitably qualified person designated by the *operator* to engage in the control and supervision of flight operations, who supports, briefs and/or assists the *pilot-in-command* in the safe conduct of the flight.

‘Flight plan’ means specified information provided to air traffic services units, relative to an intended flight or portion of a flight of an *aircraft*.

‘Flight recorder’ means any type of recorder installed in the *aircraft* for the purpose of complementing *accident/incident* investigation.

‘Flight safety documents system’ means a set of interrelated documentation established by the *operator*, compiling and organising information necessary for flight and ground operations, and comprising, as a minimum, the *operations manual* and the *operator’s maintenance control manual*.

‘Flight simulation training device’ means any one of the following three types of apparatus in which flight conditions are simulated on the ground:

- a) A *flight simulator*, which provides an accurate representation of the flight deck of a particular *aircraft* type to the extent that the mechanical, electrical, electronic, etc. *aircraft* systems control functions, the normal environment of *flight crew members*, and the performance and flight characteristics of that type of *aircraft* are realistically simulated;
- b) A *flight procedures trainer*, which provides a realistic flight deck environment, and which simulates instrument responses, simple control functions of mechanical, electrical, electronic, etc. *aircraft* systems, and the performance and flight characteristics of *aircraft* of a particular class;
- c) A *basic instrument flight trainer*, which is equipped with appropriate instruments, and which simulates the flight deck environment of an *aircraft* in flight in instrument flight conditions.

‘Flight time — helicopters’ means the total time from the moment a *helicopter’s* rotor blades start turning until the moment the *helicopter* finally comes to rest at the end of the flight, and the rotor blades are stopped.

Note - This definition is intended only for the purpose of flight and duty time regulations.

‘General aviation operation’ means the operation of an *aircraft* for any purpose other than for public transport or *aerial work*.

‘Ground handling’ means services necessary for an *aircraft’s* arrival at, and departure from, an airport, other than air traffic services.

‘Head-up display (HUD)’ means a display system that presents flight information into the pilot’s forward external field of view.

‘Helicopter’ means a heavier-than-air *aircraft* supported in flight chiefly by the reactions of the air on one or more power-driven rotors on substantially vertical axes.

‘Helideck’ means a *heliport* located on a floating or fixed offshore structure.

‘Heliport’ means an aerodrome or a defined area on a structure intended to be used wholly or in part for the arrival, departure and surface movement of *helicopters*.

Note 1 - Throughout this Part, when the term “heliport” is used, it is intended that the term also applies to aerodromes primarily meant for the use of aeroplanes.

Note 2 - Helicopters may be operated to and from areas other than heliports.

'Heliport operating minima' means the limits of usability of a *heliport* for:

- a) take-off, expressed in terms of *runway visual range* and/or visibility and, if necessary, cloud conditions;
- b) landing in 2D *instrument approach operations*, expressed in terms of visibility or *runway visual range*, or both, minimum *descent altitude or height (MDA/H)* and, if necessary, cloud conditions; and
- c) landing in 3D *instrument approach operations*, expressed in terms of visibility or *runway visual range*, or both, and *decision altitude or height (DA/H)* as appropriate to the type and/or category of the operation.

'Hostile environment' means an environment in which:

- a) a *safe forced landing* cannot be accomplished because the surface and surrounding environment are inadequate; or
- b) the *helicopter* occupants cannot be adequately protected from the elements; or
- c) search and rescue response/capability is not provided consistent with anticipated exposure; or
- d) there is an unacceptable risk of endangering persons or property on the ground.

'Human Factors principles' means principles which apply to aeronautical design, certification, training, *operations* and *maintenance* and which seek safe interface between the human and other system components by proper consideration to *human performance*.

'Human performance' means human capabilities and limitations which have an impact on the safety and efficiency of aeronautical operations.

'Incident' means an occurrence, other than an *accident*, associated with the operation of an *aircraft* which affects or could affect the safety of operation.

'Instrument approach operations' means an *approach and landing using instruments for navigation guidance based on an instrument approach procedure*, executed by a 2D or 3D instrument approach operation which are defined as follows::

- a) a two-dimensional (2D) instrument approach operation is an instrument approach operations using lateral navigation guidance only; and
- b) a three-dimensional (3D) instrument approach operation is an instrument approach operations using both lateral and vertical navigation guidance.

Note.- Lateral and vertical navigation guidance refers to the guidance provided either by:

- i) a ground-based radio navigation aid; or
- ii) computer-generated navigation data from ground-based, space-based, self-contained navigation aids or a combination of these.

‘Instrument approach procedure (IAP)’ means a series of predetermined manoeuvres by reference to flight instruments with specified protection from obstacles from –

- a) the initial approach fix; or
- b) the beginning of a defined arrival route where applicable,

to a point from which a landing can be completed and thereafter, if a landing is not completed, to a position at which holding or en-route obstacle clearance criteria apply.

‘Instrument meteorological conditions (IMC)’ means meteorological conditions expressed in terms of visibility, distance from cloud, and ceiling, less than the minima specified for *visual meteorological conditions*.

‘Integrated survival suit’ means a survival suit which meets the combined requirements of the survival suit and life jacket.

‘Landing decision point (LDP)’ means the point used in determining landing performance from which, a power-unit failure occurring at this point, the landing may be safely continued or a balked landing initiated.

Note - LDP applies only to helicopters operating in performance Class 1.

‘Maintenance’ means the performance of tasks required to ensure the continued airworthiness of an *aircraft*, including any one or combination of the following:

- a) overhaul;
- b) inspection;
- c) replacement;
- d) defect rectification; and
- e) the embodiment of a modification or *repair*.

‘Maintenance organisation’s procedures manual’ means a document endorsed by the head of the *maintenance* organisation which details the *maintenance* organisation’s structure and management responsibilities, scope of work, description of facilities, *maintenance* procedures and quality assurance or inspection systems.

‘Maintenance programme’ means a document which describes the specific scheduled *maintenance* tasks and their frequency of completion and related procedures, such as a reliability programme, necessary for the safe operation of those *aircraft* to which it applies.

‘Maintenance release’ means a document which contains a certification confirming that the *maintenance* work to which it relates has been completed in a satisfactory manner, either in accordance with the approved data and the procedures described in the *maintenance organisation’s procedures manual* or under an equivalent system.

‘Master minimum equipment list (MMEL)’ means a list established for a particular *aircraft* type by the organisation responsible for the type design with the approval of the State of Design containing items, one or more of which is permitted to be unserviceable at the commencement of a flight. The *MMEL* may be associated with special operating conditions, limitations or procedures.

‘Maximum mass’ means the maximum certificated take-off mass.

‘Minimum descent altitude (MDA) or minimum descent height (MDH)’ means a specified altitude or height in a 2D *instrument approach operation* or *circling approach operation* below which the pilot-in-command must not continue the descent without the required visual reference.

Note 1 - Minimum descent altitude (MDA) is referenced to mean sea level and minimum descent height (MDH) is referenced to the aerodrome elevation or to the threshold elevation if that is more than 2 m (7 ft) below the aerodrome elevation. A minimum descent height for a circling approach is referenced to the aerodrome elevation.

Note 2 - The required visual reference means that section of the visual aids or of the approach area which should have been in view for sufficient time for the pilot to have made an assessment of the aircraft position and rate of change of position, in relation to the desired flight path. In the case of a circling approach the required visual reference is the runway environment.

Note 3 - For convenience when both expressions are used they may be written in the form “minimum descent altitude/height” and abbreviated “MDA/H”.

‘Minimum equipment list (MEL)’ means a list which provides for the operation of *aircraft*, subject to specified conditions, with particular equipment inoperative, prepared by an *operator* in conformity with, or more restrictive than, the *MMEL* established for the *aircraft* type.

‘Night’ means the time between 20 minutes after sunset and 20 minutes before sunrise, sunset and sunrise being determined at surface level.

‘Non-congested hostile environment’ means a *hostile environment* outside a *congested area*.

‘Non-hostile environment’ means an environment in which:

- a) a *safe forced landing* can be accomplished because the surface and surrounding environment are adequate;
- b) the *helicopter* occupants can be adequately protected from the elements;
- c) search and rescue response/capability is provided consistent with anticipated exposure; and
- d) the assessed risk of endangering persons or property on the ground is acceptable.

Note - Those parts of a congested area satisfying the above requirements are considered non-hostile.

‘Obstacle clearance altitude (OCA) or obstacle clearance height (OCH)’ means the lowest altitude or the lowest height above the elevation of the relevant runway threshold or the aerodrome elevation as applicable, used in establishing compliance with appropriate obstacle clearance criteria.

Note 1 - Obstacle clearance altitude is referenced to mean sea level and obstacle clearance height is referenced to the threshold elevation or in the case of non-precision approach procedures to the aerodrome elevation or the threshold elevation if that is more than 2 m (7 ft) below the aerodrome elevation. An obstacle clearance height for a circling approach procedure is referenced to the aerodrome elevation.

Note 2 - For convenience when both expressions are used they may be written in the form “obstacle clearance altitude/height” and abbreviated “OCA/H”.

‘Offshore operations’ means *operations* which routinely have a substantial proportion of the flight conducted over sea areas to or from offshore locations. Such *operations* include, but are not limited to, support of offshore oil, gas and mineral exploitation and sea-pilot transfer.

‘Operation’ means an activity or group of activities which are subject to the same or similar hazards and which require a set of equipment to be specified, or the achievement and *maintenance* of a set of pilot competencies, to eliminate or mitigate the risk of such hazards.

Note - Such activities could include, but would not be limited to, offshore operations, heli-hoist operations or emergency medical service.

‘Operational control’ means the exercise of authority over the initiation, continuation, diversion or termination of a flight in the interest of the safety of the *aircraft* and the regularity and efficiency of the flight.

‘Operational flight plan’ means the *operator’s* plan for the safe conduct of the flight based on considerations of *helicopter* performance, other operating limitations and relevant expected conditions on the route to be followed and at the *heliports* concerned.

‘Operations in performance Class 1’ means *operations* with performance such that, in the event of a critical power-unit failure, performance is available to enable the *helicopter* to safely continue the flight to an appropriate landing area, unless the failure occurs prior to reaching the *take-off decision point (TDP)* or after passing the *landing decision point (LDP)*, in which cases the *helicopter* must be able to land within the rejected take-off or landing area.

‘Operations in performance Class 2’ means *operations* with performance such that, in the event of critical power-unit failure, performance is available to enable the *helicopter* to safely continue the flight to an appropriate landing area, except when the failure occurs early during the take-off manoeuvre or late in the landing manoeuvre, in which cases a forced landing may be required.

‘Operations in performance Class 3’ means *operations* with performance such that, in the event of a power-unit failure at any time during the flight, a forced landing will be required.

‘Operations manual’ means a manual containing procedures, instructions and guidance for use by operational personnel in the execution of their duties.

‘Operator’ means a person, organisation or enterprise engaged in or offering to engage in an *aircraft operation*.

‘Pilot-in-command’ means the pilot designated by the *operator* as being in command and charged with the safe conduct of a flight.

‘Point of no return’ means the last possible geographic point at which an aircraft can proceed to the destination aerodrome as well as to an available en-route alternate aerodrome for a given flight.

‘Psychoactive substances’ means alcohol, opioids, cannabinoids, sedatives and hypnotics, cocaine, other psychostimulants, hallucinogens, and volatile solvents, whereas coffee and tobacco are excluded.

‘Repair’ means the restoration of an aeronautical product to an airworthy condition to ensure that the *aircraft* continues to comply with the design aspects of the appropriate airworthiness requirements used for the issuance of the type certificate for the respective *aircraft* type, after it has been damaged or subjected to wear.

‘Required communication performance (RCP)’ means a statement of the performance requirements for operational communication in support of specific ATM functions.

‘Required communication performance type (RCP type)’ means a label (e.g. *RCP 240*) that represents the values assigned to *RCP* parameters for communication transaction time, continuity, availability and integrity.

‘Required navigation performance (RNP)’ means a statement of the navigation performance necessary for *operation* within a defined airspace.

Note - Navigation performance and requirements are defined for a particular RNP type and/or application.

‘Rest period’ means any period of time on the ground during which a *flight crew member* is relieved of all duties by the *operator*.

‘RNP type’ means a containment value expressed as a distance in nautical miles from the intended position within which flights would be for at least 95 per cent of the total flying time.

Example - *RNP 4* represents a navigation accuracy of plus or minus 7.4 km (4 NM) on a 95 per cent containment basis.

‘Runway visual range (RVR)’ means the range over which the pilot of an *aircraft* on the centre line of a runway can see the runway surface markings or the lights delineating the runway or identifying its centre line.

‘Safe forced landing’ means unavoidable landing or ditching with a reasonable expectancy of no injuries to persons in the *aircraft* or on the surface.

‘Safety management system (SMS)’ means a systematic approach to managing safety, including the necessary organisational structures, accountabilities, policies and procedures.

‘Series of flights’ means consecutive flights that:

- a) begin and end within a period of 24 hours; and
- b) are all conducted by the same *pilot-in-command*.

‘Serious incident’ means an *incident* involving circumstances indicating that an *accident* nearly occurred.

‘Singapore helicopter’ means a *helicopter* which is registered in the Republic of Singapore;

‘State of Registry’ means the State on whose register the *aircraft* is entered.

‘State of the Operator’ means the State in which the *operator’s* principal place of business is located or, if there is no such place of business, the *operator’s* permanent residence.

‘Take-off and initial climb phase’ means the part of the flight from the start of take-off to 300 m (1 000 ft) above the elevation of the *FATO*, if the flight is planned to exceed this height, or to the end of the climb in the other cases.

‘Take-off decision point (TDP)’ means the point used in determining take-off performance from which, a power-unit failure occurring at this point, either a rejected take-off may be made or a take-off safely continued.

Note - TDP applies only to helicopters operating in performance Class 1.

‘Visual meteorological conditions (VMC)’ means meteorological conditions expressed in terms of visibility, distance from cloud, and ceiling, equal to or better than specified minima.

‘VTOSS .’ means the minimum speed at which climb shall be achieved with the critical power-unit inoperative, the remaining power units operating within approved operating limits.

Note - The speed referred to above may be measured by instrument indications or achieved by a procedure specified in the flight manual.

2 APPLICABILITY

- 2.1 The Singapore General Aviation Requirements (SGAR) - *Helicopters* is applicable to *general aviation operations*, operated with *Singapore helicopters*.
- 2.2 The owner, *operator* and *pilot-in-command* of a *helicopter* registered in Singapore used in any *general aviation operation* have separate and distinct responsibilities in SGAR – Helicopters and they shall comply with the relevant requirements specified in this SGAR.
- 2.3 Unless otherwise notified to the *Chief Executive*, the owner of a *helicopter* will be treated as the *operator* of that *helicopter*. If the owner is not the *operator* of the *helicopter*, the owner shall notify and provide all required particulars of the *operator* to the *Chief Executive*. Such notification shall be done on Form AW148. The owner shall submit a new form to the *Chief Executive* 30 days prior to any changes to the appointment of an *operator*. An appointed *operator* shall be responsible to comply with all requirements charged under the responsibilities of the *operator* as specified in the SGAR.
- 2.4 If a *helicopter* is leased, the lessee shall take on the responsibilities of the owner in this paragraph.

CHAPTER 2

GENERAL AVIATION - HELICOPTER OPERATIONS

EFFECTIVE DATE : 11 JANUARY 2017

REVISION NO : 3 (ISSUE 1)

1 GENERAL

1.1 Compliance with laws, regulations and procedures

1.1.1 The *pilot-in-command* of a *Singapore helicopter* shall:

- a) comply with the laws, regulations and procedures of those States in which the *helicopter* is operated;
- b) be responsible for the operation and safety of the *helicopter* and for the safety of all *crew members*, passengers and cargo on board, from the moment the engine(s) are started until the *helicopter* finally comes to rest at the end of the flight, with the engine(s) shut down and rotor blades stopped;
- c) notify the appropriate local authority without delay, if an emergency situation which endangers the safety or security of the *helicopter* or persons necessitates the taking of action which involves a violation of local regulations or procedures. If required by the State in which the *incident* occurs, the *pilot-in-command* shall submit a report on any such violation to the appropriate authority of such State; in that event, the *pilot-in-command* shall also submit a copy of it to the *Chief Executive* within one working day from the time of landing;
- d) have available on board the *helicopter* the essential information concerning the search and rescue services in the area over which the *helicopter* will be flown;
- e) ensure that *flight crew members* demonstrate the ability to speak and understand the language used for aeronautical radiotelephony communications; and
- f) ensure that all baggage carried onto a *helicopter* and taken into the passenger cabin is securely stowed.

1.2 Dangerous goods

1.2.1 A *Singapore helicopter* shall not carry any *dangerous goods* except in accordance with Part VB of the ANO.

1.3 Prohibition of use of psychoactive substances

1.3.1 No member of a *flight crew* shall not perform any function specified in the privileges applicable to his licence if he is under the influence of any psychoactive substance which may render him unable to perform such functions in a safe and proper manner.

1.3.2 No person whose function is critical to the safety of aviation (safety-sensitive personnel) shall undertake that function while under the influence of any psychoactive

substance, by reason of which *human performance* is impaired. No such person shall engage in any kind of problematic use of substances.

1.4 Reporting of accidents, incidents and occurrences

1.4.1 *Operators, pilots-in-command* and *maintenance* organisations of Singapore registered *helicopter* are required to report any *accidents, incidents* or occurrences which endangers, or unless corrected would have endangered the *flight crew* and passengers and *helicopter* (such as unlawful interference, air rage etc). The written report is to be submitted to the *Chief Executive* as follows:

- a) *Accident* – report by phone immediately to the Airworthiness and Flight Operations Division Duty Officer followed by written (fax) report within three hours of the occurrence of the *accident*.
- b) *Serious Incident* – report within one working day from time upon landing.
- c) *Incident* - report within three working days from time upon landing.

1.4.2 The *pilot-in-command* of a *Singapore helicopter* shall report any hazardous conditions, other than those associated with meteorological conditions, to the appropriate aeronautical station as soon as possible. The reports so rendered shall give such details as may be pertinent to the safety of other *aircraft*.

1.4.3 The *pilot-in-command* of a *Singapore helicopter* shall be responsible for reporting all known or suspected defects in the *aircraft* to the *operator* at the termination of the flight in accordance with SAR Chapter 4.5.

2 FLIGHT OPERATIONS

2.1 Adequacy of operating facilities

2.1.1 The *pilot-in-command* of a *Singapore helicopter* shall not commence a flight unless it has been ascertained by every reasonable means available that the ground and/or water facilities available and directly required for such flight and for the safe operation of the *helicopter* are adequate including communication facilities and navigation aids.

2.2 *Helicopter operating minima*

2.2.1 The *pilot-in-command* of a *Singapore helicopter* shall not operate to or from a *heliport* using operating minima lower than those which may be established for that *heliport* by the State in which it is located, except with the specific approval of that State.

Note – Operations with lower visibilities than normally associated with the heliport operating minima may only be allowed on a helicopter with HUD and/or EVS if approval has been obtained in accordance to paragraph 4.12.1.

2.3 Briefing

2.3.1 The *pilot-in-command* of a *Singapore helicopter* shall ensure that *crew members* and passengers are made familiar by means of an oral briefing or by other means, with the location and use of:

- a) seat belts;
- b) emergency exits;
- c) life jackets, if the carriage of life jackets is prescribed;
- d) oxygen dispensing equipment; and
- e) other emergency equipment provided for individual use, including passenger emergency briefing cards.

2.3.2 The *pilot-in-command* of a *Singapore helicopter* shall ensure that all persons on board are aware of the location and general manner of use of the principal emergency equipment carried for collective use.

2.4 *Helicopter Airworthiness and safety precautions*

2.4.1 A flight shall not be commenced until the *pilot-in-command* of a *Singapore helicopter* is satisfied that:

- a) the *helicopter* is airworthy, duly registered and that appropriate certificates as required under the Air Navigation Order are aboard the *helicopter*;
- b) the instruments and equipment installed in the *helicopter* are appropriate, taking into account the expected flight conditions;
- c) any necessary *maintenance* has been performed in accordance with Section 6 of this Chapter;
- d) the mass of the *helicopter* and centre of gravity location are such that the flight can be conducted safely, taking into account the flight conditions expected;

- e) any load carried is properly distributed and safely secured; and
- f) the *helicopter* operating limitations contained in the *flight manual*, or its equivalent, will not be exceeded.

2.5 Weather Reports and Forecasts

2.5.1 A flight shall not be commenced unless the *pilot-in-command* of a *Singapore helicopter* is familiar with all available *meteorological information* appropriate to the intended flight. Preparation for a flight away from the vicinity of the place of departure, and for every flight under the instrument flight rules, shall include:

- a) a study of available current weather reports and forecasts; and
- b) the planning of an alternative course of action to provide for the eventuality that the flight cannot be completed as planned because of weather conditions.

2.6 Limitations imposed by weather conditions

2.6.1 Flight in accordance with VFR

2.6.1.1 A flight, except one of purely local character in *visual meteorological conditions*, to be conducted in accordance with VFR shall not be commenced unless available current meteorological reports, or a combination of current reports and forecasts, indicate that the meteorological conditions along the route, or that part of the route to be flown under VFR, will, at the appropriate time, be such as to render compliance with these rules possible.

2.6.2 Flight in accordance with IFR

2.6.2.1 When an alternate is required

A flight to be conducted in accordance with IFR shall not be commenced unless the available information indicates that conditions, at the *heliport* of intended landing and at least one *alternate heliport* will, at the estimated time of arrival, be at or above the *heliport operating minima*.

2.6.2.2 When no alternate is required

A flight to be conducted in accordance with IFR to a *heliport* when no *alternate heliport* is required shall not be commenced unless available current meteorological information indicates that the following meteorological conditions will exist from two hours before to two hours after the estimated time of arrival, or from the actual time of departure to two hours after the estimated time of arrival, whichever is the shorter period:

- a) a cloud base of at least 120 m (400 ft) above the minimum associated with the instrument approach procedure; and
- b) visibility of at least 1.5 km more than the minimum associated with the procedure.

2.6.3 Heliport operating minima

2.6.3.1 A flight shall not be continued towards the *heliport* of intended landing unless the latest available meteorological information indicates that conditions at that *heliport*, or at least one *alternate heliport*, will, at the estimated time of arrival, be at or above the specified *heliport operating minima*.

2.6.3.2 An instrument approach shall not be continued below 300m (1000 ft) above the heliport elevation or into *the final approach segment* unless the reported visibility or controlling RVR is at or above the heliport minima.

Note : Criteria for the Final Approach Segment is contained in PANS-OPS (Doc 8168), Volume II.

2.6.3.3 If after entering the *final approach segment* or after descending below 300m (1000ft) above the *heliport* elevation the reported visibility or controlling RVR falls below the specified minimum, the approach may be continued to *DA/H* or *MDA/h*. In any case, a *helicopter* shall not continue its approach to land beyond a point at which the limits of the *heliport operating minima* would be infringed.

2.6.4 Flight in icing conditions

2.6.4.1 A flight to be operated in known or expected icing conditions shall not be commenced unless the *helicopter* is certificated and equipped to cope with such conditions.

2.7 **Alternate heliports**

2.7.1 For a flight to be conducted in accordance with IFR, at least one suitable alternate shall be specified in the *operational flight plan* and the *flight plan*, unless:

- a) the weather conditions in 2.6.2.2 prevail; or
- b)
 - 1) the *heliport* of intended landing is isolated and no suitable alternate is available; and
 - 2) an instrument approach procedure is prescribed for the isolated *heliport* of intended landing; and
 - 3) a *point of no return (PNR)* is determined in case of an offshore destination.

2.7.2 Suitable offshore alternates shall be specified subject to the following:

- a) the offshore alternates shall be used only after a *PNR*. Prior to a *PNR*, onshore alternates shall be used;
- b) mechanical reliability of the critical control systems and critical components shall be considered and taken into account when determining the suitability of alternates;
- c) one engine inoperative (OEI) performance capability shall be attainable prior to arrival at the alternate;
- d) to the extent possible, deck availability shall be guaranteed; and
- e) weather information should be reliable and accurate.

2.7.3 Offshore alternates should not be used when it is possible to carry enough fuel to have an onshore alternate. Offshore alternates should not be used in a *hostile environment*.

2.8 Fuel and oil supply

2.8.1 All helicopters

2.8.1.1 A flight shall not be commenced unless, taking into account both the meteorological conditions and any delays that are expected in flight, the *helicopter* carries sufficient fuel and oil to ensure that it can safely complete the flight. In addition a reserve shall be carried to provide for contingencies.

2.8.2 VFR Operations

2.8.2.1 The fuel and oil supply carried in order to comply with 2.8.1 shall, in the case of VFR operations be at least the amount sufficient to allow the *helicopter*:

- a) to fly to the heliport to which the flight is planned;
- b) to fly, thereafter, for a period of 20 minutes at best range speed;
- c) to have an additional amount of fuel to provide for the increased consumption on the occurrence of any of the potential contingencies specified listed in the *Operations Manual* and approved by the *Chief Executive*.

2.8.3 IFR Operations

The fuel and oil carried in order to comply with 2.8.1 shall, in the case of IFR operations, be at least the amount sufficient to allow the *helicopter*:

2.8.3.1 When no alternate is required, in terms of 2.6.2.2, to fly to the heliport to which the flight is planned, and thereafter:

- a) to fly for 30 minutes at holding speed at 450m (1500') above the destination heliport under standard temperature conditions and approach and land; and
- b) to have additional amount of fuel, sufficient to provide for the increased consumption on the occurrence of any of the potential contingencies as specified by the *operator*.

2.8.3.2 When an alternate is required, in terms of 2.6.2.1, to fly to and execute an approach, and a missed approach, at the *heliport* to which the flight is planned, and thereafter:

- a) to fly to the alternate specified in the *flight plan*; and then
- b) to fly for 30 minutes at holding speed at 450 m (1 500 ft) above the alternate under standard temperature conditions, and approach and land; and
- c) to have an additional amount of fuel, sufficient to provide for the increased consumption on the occurrence of potential contingencies.

2.8.3.3 When no suitable alternate is available, e.g. when the destination is isolated, sufficient fuel shall be carried by the *helicopter* to fly to the destination to which the flight is planned and thereafter for a period that will, based on geographic and environmental considerations, enable a safe landing to be made.

2.8.4 In computing the fuel and oil required in 2.8.1, at least the following shall be considered:

- a) meteorological conditions forecast;

- b) expected air traffic control routings and traffic delays;
- c) for IFR flight, one instrument approach at the destination heliport, including a missed approach;
- d) the procedures prescribed in the *operations manual* for loss of pressurisation, where applicable, or failure of one power unit while *en-route*; and
- e) any other conditions that may delay the landing of the *helicopter* or increase its fuel/ or oil consumption.

2.9 Oxygen supply

2.9.1 A flight to be operated at altitudes at which the atmospheric pressure in personnel compartments will be less than 700 hPa shall not be commenced unless sufficient stored breathing oxygen is carried to supply:

- a) all *crew members* and 10 % of the passengers for any period in excess of 30 minutes that the pressure in the compartments occupied by them will be between 700 hPa and 620 hPa;
- b) the crew and passengers for any period that the atmospheric pressure in compartments occupied by them will be less than 620 hPa.

Note 1 - Guidance on the carriage and use of oxygen is given in Appendix B of this chapter.

Note 2 - Approximate altitudes in the Standard Atmosphere corresponding to the values of absolute pressure used in the text of Appendix C as follows:

| Absolute pressure | Metres | Feet |
|-------------------|--------|--------|
| 700 hPa | 3 000 | 10 000 |
| 620 hPa | 4 000 | 13 000 |

2.9.2 A flight to be operated with a pressurised *helicopter* shall not be commenced unless a sufficient quantity of stored breathing oxygen is carried to supply all the crew members and passengers, as is appropriate to the circumstances the flight being undertaken, in the event of loss of pressurisation, for any period that the atmospheric pressure in any compartment occupied by them would be less than 700 hPa.

2.10 Use of oxygen

2.10.1 All *flight crew members*, when engaged in performing duties essential to the safe operation of an *helicopter* in flight, shall use breathing oxygen continuously whenever the circumstances prevail for which its supply has been prescribed in 2.9.

2.11 In-flight emergency instruction

2.11.1 In an emergency during flight, the *pilot-in-command* shall ensure that all persons on board are instructed in such emergency action as may be appropriate to the circumstances.

2.12 Weather reporting by pilots

2.12.1 When weather conditions likely to affect the safety of other *aircraft* are encountered, they should be reported as soon as possible.

2.13 Hazardous flight conditions

2.13.1 Hazardous flight conditions encountered, other than those associated with meteorological conditions, should be reported to the appropriate aeronautical station as soon as possible. The reports so rendered should give such details as may be pertinent to the safety of other *aircraft*.

2.14 Fitness of *flight crew members*

2.14.1 The *pilot-in-command* of a *Singapore helicopter* shall be responsible for ensuring that a flight:

- a) will not be commenced if any *flight crew member* is incapacitated from performing duties by any cause such as injury, sickness, fatigue, the effects of alcohol or drugs; and
- b) will not be continued beyond the nearest suitable heliport when *crew members'* capacity to perform functions is significantly reduced by impairment of faculties from causes of fatigue, sickness or lack of oxygen.

2.15 *Flight crew members at duty stations*

2.15.1 Take-off and landing - All *flight crew members* required to be on flight deck duty shall be at their stations.

2.15.2 En route - All *flight crew members* required to be on flight deck duty shall remain at their stations except when their absence is necessary for the performance of duties in connection with the operation of the *helicopter* or for physiological needs.

2.15.3 Seat belts - All *flight crew members* shall keep their seat belts fastened when at their stations.

2.15.4 Safety harness - When safety harnesses are provided, any *flight crew member* occupying a pilot's seat shall keep the safety harness fastened during the take-off and landing phases; all other *flight crew members* shall keep their safety harnesses fastened during the take-off and landing phases unless the shoulder straps interfere with the performance of their duties, in which case the shoulder straps may be unfastened but the seat belt must remain fastened.

2.16 Instrument flight procedures

2.16.1 One or more *instrument approach procedures* designed to support *instrument approach operations* shall be approved and promulgated by the State in which the *heliport* is located, or by the State which is responsible for the *heliport* when located outside the territory of any State, to serve each *final approach and take-off area* or *heliport* utilised for instrument flight operations.

2.16.2 All *Singapore helicopters* operated in accordance with IFR shall comply with the instrument approach procedures approved by the State in which the *heliport* is located, or by the State which is responsible for the *heliport* when located outside the territory of any State.

2.17 Instruction – general

2.17.1 A *helicopter* rotor shall not be turned under power for the purpose of flight without a qualified pilot at the controls.

2.18 Refueling with passenger on board or rotors turning

- 2.18.1 A *Singapore helicopter* should not be refueled when passengers are embarking, onboard or disembarking when the rotor is turning unless it is specifically authorised by *pilot-in-command* or unless other qualified personnel are ready to initiate and direct an evacuation of the *helicopter* by the most practical and expeditious means available.
- 2.18.2 When refueling with passengers on board, two-way communications should be maintained by the *helicopter's* intercommunication system or other suitable means between the ground crew supervising the refueling and the *pilot-in-command* or other qualified personnel required by 2.17.1.

2.19 Over-water flights

- 2.19.1 All *helicopters* on flights over-water in a *hostile environment* in accordance with para 4.3.1 shall be certificated for ditching. Sea state shall be an integral part of the ditching information.

3 HELICOPTER PERFORMANCE OPERATING LIMITATIONS

3.1 General

- 3.1.1 A *Singapore helicopter* shall be operated:
- a) in compliance with the terms of its Certificate of Airworthiness or equivalent approved document and *Operations Manual* (see Appendix C),;
 - c) within the operating limitations specified by the *Chief Executive*, including the performing classes; and
 - d) if applicable, within the mass limitations imposed by compliance with the applicable noise certificate issued by the *Chief Executive*, unless otherwise authorised in exceptional circumstances for a certain *aerodrome* or a *heliport* where there is no noise disturbance problem, by the competent authority of the State in which the *aerodrome/ heliport* is situated.
- 3.1.2 The *helicopter* shall have displayed on it such placards, listings, instrument markings, or combinations thereof, containing operating limitations, as may be notified to the *operator*, for visual presentation.
- 3.1.3 Where *helicopters* are operating to or from heliports in a *congested hostile environment*, the competent authority of the State in which the heliport is situated shall take such precautions as are necessary to control the risk associated with a power-unit failure.
- 3.1.4 The *pilot-in-command* of a *Singapore helicopter* shall determine that *helicopter's* performance will permit the take-off and departure to be carried out safely. In conditions where the safe continuation of flight is not ensured in the event of a critical power unit failure, *helicopter* operations shall be conducted in a manner that gives appropriate consideration for achieving a *safe forced landing*.
- 3.1.5 All operations carried out with *Singapore helicopters* shall be conducted under *performance Classes 1, 2 or 3* in accordance to the following:
- a) *Helicopters* certificated in Category A can be operated under *performance class 1, 2 or 3*,
 - b) *Helicopters* certificated in either Category B shall be operated under *performance class 3*,
 - c) *Operations in performance class 2* can be conducted with a *helicopter* with a safe landing capability during take-off and landing,
 - d) *Helicopter* with a passenger seating configuration of more than 19 shall be operated in performance Class 1,
 - e) *Helicopters* with a passenger seating configuration of 19 or less but more than 9 must be operated in performance Class 1 or 2,
 - f) *Helicopters* with a passenger seating configuration of 9 or less can be operated in performance Class 1, 2 or 3.

- g) Performance Class 3 operations are not to be performed when
- 1) out of the sight of the surface; or
 - 2) at *night*; or
 - 3) when the *cloud* ceiling is less than 180 m (600 ft).

3.1.7 The requirements in 3.1.6 are summarised below -

| Conditions | Performance Class 1 | Performance Class 2* | Performance Class 3 |
|-------------------------------------------------------------------------------|----------------------------|-----------------------------|----------------------------|
| <i>Helicopter</i> certificated to Category A | Yes | Yes | Yes |
| <i>Helicopter</i> certificated to Category B | No | No | Yes |
| Operations to or from <i>heliport</i> in <i>congested hostile environment</i> | Yes | No | No |
| Passenger seating configuration of more than 19 | Yes | No | No |
| Passenger seating configuration of more than 9 but less than 19 | Yes | Yes | No |
| Passenger seating configuration of 9 or less | Yes | Yes | Yes |
| When out of sight of the surface | Yes | Yes | No |
| <i>At night</i> | Yes | Yes | No |
| When cloud ceiling is less than 180m (600ft) | Yes | Yes | No |

* *Operations in performance class 2* can be conducted with a safe landing capability during take-off and landing

Note - Appendix A comprises material that is provided for the purpose of guidance for establishing its code of performance.

3.2 Mass Limitations

- 3.2.1 The mass of a *Singapore helicopter* at the start of its take-off shall not exceed the maximum take-off mass.
- 3.2.2 In no case shall the estimated mass for the expected time of landing at the destination and any alternate exceed the maximum landing mass specified in the *helicopter flight manual* taking into consideration as a minimum, factors such as pressure-altitude, temperature, elevation, wind and surface conditions.
- 3.2.3 *Take-off and initial climb phase*
- 3.2.3.1 *Operations in performance Class 1*
 The *helicopter* shall be able in the event of the failure of the critical power unit being recognised at or before the *take-off decision point* to discontinue the take-off and stop within the rejected take-off area available or, in the event of the failure of the critical

power unit being recognised at or after the take-off decision point, to continue the take-off, clearing all obstacles along the flight paths by an adequate margin until the *en-route* phase.

3.2.3.2 Operations in performance Class 2

The *helicopter* shall be able, in the event of the failure of the critical power unit at any time after *DPATO*, to continue the take-off, clearing all obstacles along the flight path until the *en-route* phase. Before the *DPATO*, the failure of the critical power unit may cause the *helicopter* to force-land; therefore the conditions stated in 3.1.5 shall apply.

3.2.3.3 Operations in performance Class 3

At any point of the flight path, failure of a power unit will cause the *helicopter* to force-land; therefore the conditions stated in 3.1.5 shall apply.

3.2.4 En-route phase

3.2.4.1 Operations in performance Class 1 and 2

The *helicopter* shall be able, in the event of the failure of the critical power unit at any point in the *en-route* phase, to continue the flight to a site at which the conditions of 3.2.3.1 for *operations in performance Class 1*, or the conditions of 3.2.3.2 in *performance Class 2* can be met, without flying below the appropriate flight altitude at any point.

3.2.4.2 Operations in performance Class 3

The *helicopter* shall be able, with all the power units operating, to continue along its intended route or planned diversions without flying at any point below the appropriate minimum flight altitude. At any point of the flight path, failure of a power unit will cause the *helicopter* to force-land; therefore the conditions stated in 3.1.5 shall apply.

3.2.5 Approach and Landing phase

3.2.5.1 Operations in performance Class 1

In the event of the failure of the critical power-unit being recognised at any point during the approach and landing phase, before the *landing decision point*, the *helicopter* shall, at the destination and at any alternate, after clearing all obstacles in the approach path, be able to land and stop within the landing distance available or to perform a bailed landing and clear all obstacles in the flight path by an adequate margin equivalent to that specified in 3.2.3.1. In the case of failure occurring after the *landing decision point*, the *helicopter* shall be able to land and stop within the landing distance available.

3.2.5.2 Operations in performance Class 2

In the event of the failure of the critical power unit before the *DPBL*, the *helicopter* shall, at the destination and at any alternate, after clearing all obstacles in the approach path, be able either to land and stop within the landing distance available or to perform a bailed landing and clear all the obstacles in the flight path by an adequate margin equivalent to that specified in 3.2.3.2. After the *DPBL*, failure of a power unit may cause the *helicopter* to force-land; therefore the conditions stated in 3.1.5 shall apply.

3.2.5.3 Operations in performance Class 3

At any point of the flight path, failure of a power unit will cause the *helicopter* to force-land; therefore the conditions in 3.1.5 shall apply.

3.3 Obstacle Data

- 3.3.1 All available obstacle data should be used to develop procedures to comply with the take-off, initial climb, approach and landing phases.

4 HELICOPTER INSTRUMENTS, EQUIPMENT AND FLIGHT DOCUMENTS

4.1 All helicopters on all flights

4.1.1 General

4.1.1.1 In addition to the minimum equipment necessary (*Minimum Equipment List*) for the issuance of a certificate of airworthiness, the instruments, equipment and flight documents prescribed in the following paragraphs shall be installed or carried, as appropriate, in *helicopters* according to the *helicopter* used and to the circumstances under which the flight is to be conducted. The prescribed instruments and equipment, including their installation, shall be acceptable to the *Chief Executive*.

Note - Appendix D contains guidance on the Minimum Equipment List (MEL).

4.1.2 Instruments

4.1.2.1 A *Singapore helicopter* shall be equipped with instruments which will enable the *flight crew* to control the flight path of the *helicopter*, carry out any required procedural manoeuvre, and observe the operating limitations of the *helicopter* in the expected operating conditions.

4.1.3 Equipment

4.1.3.1 A *Singapore helicopter* shall, on all flights, be equipped with:

- a) one or more accessible first-aid kits, as appropriate to the number of passengers it is authorised to carry (see Appendix F);
- b) portable fire extinguishers of a type which, when discharged, will not cause dangerous contamination of the air within the *helicopter*. At least one shall be located in:
 - 1) the pilot's compartment; and
 - 2) each passenger compartment that is separate from the pilot's compartment and not readily accessible to the pilot or co-pilot;
- c)
 - 1) a seat or berth for each person over an age of two years;
 - 2) a seat belt for each seat and restraining belts for each berth; and
 - 3) a safety harness for each flight crew seat. The safety harness for each pilot seat shall incorporate a device which will automatically restrain the occupant's torso in the event of rapid deceleration.
- d) the following manuals, charts and information:
 - 1) the *Operator's Manual*;
 - 2) the *flight manual* or other documents or information concerning any operating limitations prescribed for the *helicopter* by the *Chief Executive*;
 - 3) current and suitable charts for the route of the proposed flight and any route along which it is reasonable to expect that the flight may be diverted;

- 4) procedures for pilots-in-command of intercepted *aircraft*;
 - 5) visual signals for use by intercepting and intercepted *aircraft*, and
 - 6) the journey log book for the *helicopter*.
- e) where the *helicopter* is fitted with fuses that are accessible in flight, spare electrical fuses of appropriate ratings for replacement of those fuses; and
- f) ground-air signal codes for search and rescue purposes. Placards or other means of ensuring that the following information and instructions are conveyed to passengers:
- 1) when seat belts or harnesses are to be fastened;
 - 2) when and how oxygen equipment is to be used if carried;
 - 3) restrictions on smoking;
 - 4) location and use of life jackets or equivalent individual flotation devices where their carriage is required; and location and method of opening emergency exits.

4.1.4 Marking of break- in points

4.1.4.1 If areas of the fuselage suitable for break-in by rescue crews in emergency are marked on a *Singapore helicopter*, such areas shall be marked as shown below (see figure following). The colour of the markings shall be red or yellow, and if necessary they shall be outlined in white to contrast with the background.

4.1.4.2 If the corner markings are more than 2 m apart, intermediate lines 9 cm x 3 cm shall be inserted so that there is no more than 2 m between adjacent markings.

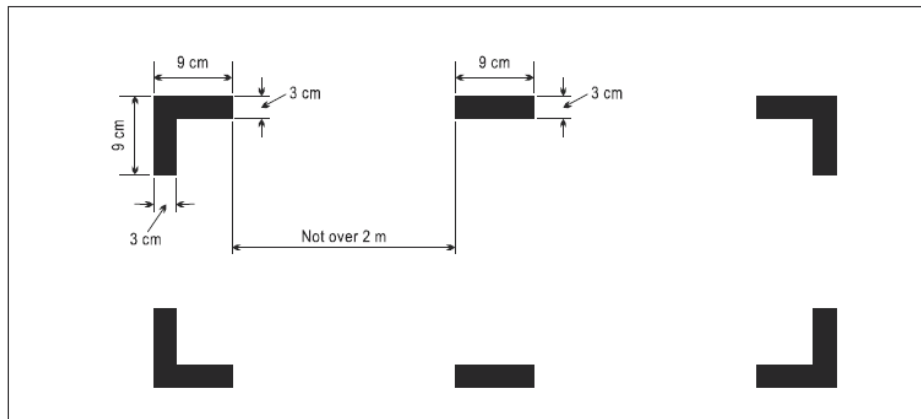

MARKINGS OF BREAK-IN POINTS

4.2 Instruments and equipment for flights operated under VFR and IFR – by day and *night*.

4.2.1 All *Singapore helicopters* shall, when operated as VFR flights, be equipped with:

- a) a means of measuring and displaying:
 - 1) magnetic heading;

- 2) the time in hours, minutes and seconds;
 - 3) pressure altitude;
 - 4) indicated airspeed; and
- b) such additional equipment as may be prescribed by the *Chief Executive*.

4.2.2 All *Singapore helicopters* shall, when operating in accordance with VFR at *night*, be equipped with:

- a) the equipment specified in 4.2.1;
- b) an attitude indicator for each pilot plus one additional attitude indicator;
- c) a slip indicator;
- d) a heading indicator (directional gyroscope);
- e) a rate of climb and descent indicator;
- f) the lights required in the ANO for operating the *helicopter* in flight or operating on the movement area of an aerodrome or *heliport*;
- g) two landing lights of which 1 is trainable in the vertical plane;
- h) illumination for all instruments and equipment that are essential for the safe operation of the *helicopter*;
- i) lights in all passenger compartments;
- j) a flashlight for each *crew member* station, and
- k) such additional instruments or equipment as may be prescribed by the *Chief Executive*.

4.2.3 All *Singapore helicopters* shall, when operating in accordance with IFR, or when the *helicopter* cannot be maintained in a desired attitude without reference to one or more flight instruments, be equipped with:

- a) a means of measuring and displaying magnetic heading;
- b) a means of measuring and displaying the time in hours, minutes and seconds;
- c) two sensitive pressure altimeters, which are not drum-pointer altimeters;
- d) an airspeed indicating system with means of preventing malfunctioning due to condensation or icing;
- e) a slip indicator;
- f) an attitude indicator (artificial horizon) for each required pilot and one additional attitude indicator;
- g) a heading indicator (directional gyroscope);
- h) a means of indicating whether the power supply to the gyroscope instrument is adequate;

- i) a means of indicating in the flight crew compartment the outside air temperature;
- j) a rate of climb and descent indicator;
- k) an emergency power supply independent of the electrical generating system, for the purpose of operating and illuminating, for a minimum period of 30 minutes, an attitude indicating instrument (artificial horizon), clearly visible to the *pilot-in-command*. The emergency power supply should be automatically operative after the total failure of the main electrical generating system and clear indication shall be given on the instrument panel that the attitude indicator is being operated by emergency power.
- l) such additional instruments or equipment as may be prescribed by the *Chief Executive*; and
- m) if operated at *night*, the lights specified in 4.2.2 (f) to (j).

4.3 All helicopters on flights over water

4.3.1 Means of flotation

4.3.1.1 All *Singapore helicopters* shall, when intended to be flown over water, be fitted with a permanent or rapidly deployable means of flotation so as to ensure a safe ditching of the *helicopter* when:

- a) engaged in *offshore operations*, or other overwater operations;
- b) flying in the following conditions -
 - 1) flying over water in a *hostile environment* at a distance from land corresponding to more than 10 minutes at normal cruise speed when operating in *performance Class 1 or 2*;
 - 2) flying over water in a *non-hostile environment* at a distance from land specified by the *Chief Executive* when operating in *performance Class 1*; or
 - 3) flying over water beyond auto-rotational or *safe forced landing* distance from land when operating in *performance Class 3*.

4.3.2 Emergency Equipment

4.3.2.1 *Singapore helicopters* operating in *performance Class 1 and 2* and operating in accordance to the provisions of 4.3.1 shall be equipped with:

- a) one life jacket, or equivalent individual flotation device, for each person onboard, stowed in a position easily accessible from the seat or berth of the person for whose use it is provided.
- b) life saving rafts in sufficient numbers to carry all the persons on board, stowed so as to facilitate their ready use in emergency, provided with such life-saving equipment including means of sustaining life as it is appropriate to the flight to be undertaken. At least 50% of the life rafts should be deployable by remote control. Rafts which are not deployable by remote control and which have a mass of more than 40 kg should be equipped with some means of mechanically assisted deployment.

- c) equipment for making the pyrotechnic distress signals specified in the Air Navigation Order.

4.3.2.2 *Singapore helicopters* operating in *performance Class 3* when operating beyond auto-rotational distance from land but within a distance from land specified by the responsible authority shall be equipped with a jacket, or equivalent individual flotation device, for each person on board, stowed in a position easily accessible from the sea or berth if the person for whose use it is provided. Consideration should be given to environmental conditions and the availability of search and rescue facilities when determining the distance from land. For *offshore operations*, when operating beyond auto-rotational distance from land, the life jacket should be worn unless the occupant is wearing an *integrated survival suit* that includes the functionality of the life jacket.

4.3.2.3 *Singapore helicopters* operating in *performance Class 3* when operating beyond the distance specified in 4.3.2.2 should be equipped as in 4.3.2.1.

4.3.2.4 In the case of *helicopters* operating in *performance Class 2 or 3*, when taking off or landing at a *heliport*, the take-off or approach path is so disposed over water that in the event of mishap there would be a likelihood of a ditching; at least the equipment required in 4.3.2.1a shall be carried.

4.3.2.5 Each life jacket and equivalent individual flotation device, when carried in accordance to 4.3.2, shall be equipped with a means of electric illumination for the purpose of facilitating the location of persons.

4.4 Helicopters on flights over designated areas

4.4.1 *Singapore helicopters*, when operated across land or sea areas which have been designated by the relevant authority concerned as areas in which search and rescue would be especially difficult, shall be equipped with such signaling devices and life-saving equipment (including means of sustaining lives) as may be appropriate to the area over flown.

4.5 All helicopters on high altitude flights

4.5.1 Unpressurised *helicopters* intended to be operated at high altitudes shall carry equipment for storing and dispensing the oxygen supplies required in 2.9.1.

4.5.2 Pressurised *helicopters* intended to be operated at high altitudes should carry emergency oxygen storage and dispensing equipment capable of storing and dispensing the oxygen supplies required in 2.9.2.

4.6 All helicopters required to comply with the noise certification standards

4.6.1 All *Singapore helicopters* required to comply with Para 51 of the Air Navigation Order shall carry the noise certificate onboard.

4.7 Flight recorders

4.7.1 Refer to the Singapore Airworthiness Requirements.

4.8 Emergency Locator Transmitter (ELT)

4.8.1 All *Singapore helicopters* operating in *performance Class 1 and 2* shall be equipped with at least one automatic *ELT*, and when operating on flights over water as

described in 4.3.1 a) with at least one automatic *ELT* and one *ELT(S)* in a raft or life-jacket.

- 4.8.2 All *Singapore helicopters* operating in *performance Class 3* shall be equipped with at least one automatic *ELT* and when operating on flights over water as described in 4.3.1 b) with at least one automatic *ELT* and one *ELT(S)* in a raft or life-jacket.
- 4.8.3 All *helicopters* shall carry an automatic *emergency locator transmitter (ELT)* that operates simultaneously on 406 MHz and 121.5 MHz.
- 4.8.4 *ELT* equipment carried to satisfy the requirements of 4.8.1 and 4.8.2 shall operate in accordance with the relevant provisions of Volume III to Annex 10 to the Convention on International Civil Aviation.

4.9 Helicopters required to be equipped with a pressure-altitude reporting transponder

- 4.9.1 All *Singapore helicopters* shall be equipped with a pressure-altitude reporting transponder which operates in accordance with the relevant provisions of Volume IV to the Annex 10 to the International Convention on Civil Aviation and the Air Navigation Order.

4.10 Microphones

- 4.10.1 All *flight crew members* on flight deck duty shall communicate through boom or throat microphones.

4.11 Helicopters carrying passengers

- 4.11.1 All *helicopters* shall be equipped with a *forward* or rearward facing seat, fitted with a safety harness for the use of each cabin crew.
- 4.11.2 Cabin crew seats shall be located near floor level and other emergency exits as required for emergency evacuation.

4.12 Helicopters equipped with head-up displays (HUD) and/or enhanced vision systems (EVS)

- 4.12.1 Where a *Singapore helicopter* is equipped with *HUD* and/or *EVS*, such systems shall not be used to gain operational credits unless approved by the *Chief Executive*.

Note – Guidance on HUD and EVS is contained in relevant advisory circulars.

5 HELICOPTER COMMUNICATION AND NAVIGATION EQUIPMENT

5.1 Communication equipment

- 5.1.1 A *Singapore helicopter* shall be provided with radio communication capable of
- a) conducting two-way communication for *heliport* control purposes;
 - b) receiving meteorological information at any time during flight;
 - c) conducting two-way communication at any time during flight with at least one aeronautical station and with such aeronautical stations and on such frequencies as prescribed by the *Chief Executive*, including the aeronautical emergency frequency 121.5 Mhz.
- 5.1.2 When compliance with 5.1.1 requires that more than one communication equipment unit be provided, each shall be independent of the other or others to the extent that a failure in any one will not result in failure of any other.
- 5.1.3 For flights in defined portions of airspace or on routes where an *RCP type* has been specified, a *helicopter* shall, in addition to the requirements specified in 5.1.1 to 5.1.2:
- a) be provided with communication equipment which will enable it to operate in accordance with the prescribed *RCP type(s)*; and
 - b) be authorised by the *Chief Executive* for operations in such airspace.

5.2 Navigation equipment

- 5.2.1 A *Singapore helicopter* shall be provided with navigation equipment which will enable it to proceed:
- a) in accordance with its *operational flight plan*; and
 - b) in accordance with the requirements of air traffic services; except when, if not so precluded by the *Chief Executive*, navigation for flights under VFR is accomplished by visual reference to landmarks. These landmarks shall be located at least every 110km (60NM).
- 5.2.2 No *Singapore helicopter* shall operate in airspace in which a navigation specification for performance-based navigation has been specified by the relevant authority, unless it, in addition to the requirements specified in 5.2.1:
- a) is authorised by the *Chief Executive* for such operations; and
 - b) is provided with navigation equipment which will enable it to operate in accordance with the prescribed *RNP type(s)*.
- 5.2.3 The *helicopter* shall be sufficiently provided with navigation equipment to ensure that, in the event of the failure of one item of equipment at any stage of the flight, the remaining equipment will enable the *helicopter* to navigate in accordance with 5.2.1 and where applicable 5.2.2.
- 5.2.4 On flights in which it is intended to land in *instrument meteorological conditions*, a Singapore- registered *helicopter* shall be provided with appropriate navigation equipment capable of providing guidance to a point from which a visual landing can be effected. This equipment shall be capable of providing such guidance for each

aerodrome/ heliport at which it is intended to land in instrument meteorological conditions and for any designated alternate aerodrome/ heliports.

6 HELICOPTER MAINTENANCE

6.1 Owner's maintenance responsibilities

6.1.1 The owner of a *Singapore helicopter*, or in the case where it is leased, the lessee, shall ensure that:

- a) the *helicopter* is maintained in an airworthy condition;
- b) the operational and emergency equipment necessary for an intended flight is serviceable;
- c) the Certificate of Airworthiness of the *helicopter* remains valid; and
- d) the *maintenance* of the *helicopter* is performed in accordance with a *maintenance programme* acceptable to the Chief Executive.

6.1.2 The *helicopter* shall not be operated unless it is maintained and released to service in accordance with the Singapore Airworthiness Requirements (SAR).

6.2 Maintenance records

6.2.1 The owner of a *Singapore helicopter*, or in the case where it is leased, the lessee, shall ensure that the following records are kept for the periods mentioned in 6.2.2:

- a) the total time in service (hours, calendar time and cycles, as appropriate) of the *helicopter* and all life limited components;
- b) the current status of compliance with all applicable mandatory continuing airworthiness information;
- c) appropriate details of modifications and *repairs*;
- d) the time in service (hours, calendar time and cycles, as appropriate) since the last overhaul of the *helicopter* or its components subject to a mandatory overhaul life;
- e) the current status of the *helicopter's* compliance with the *maintenance programme*; and
- f) the detailed *maintenance* records to show that all requirements for the signing of a *maintenance release* have been met.

6.2.2 The records shall be kept for a minimum period of 2 years after the unit to which they refer has been permanently withdrawn from service.

6.2.3 In the event of a temporary change of owner or lessee, the records shall be made available to the new owner or lessee. In the event of any permanent change of owner or lessee, the records shall be transferred to the new owner or lessee.

6.3 Continuing airworthiness information

6.3.1 The owner of a *helicopter* over 3 175 kg maximum certificated take-off mass, or in the case where it is leased, the lessee, shall, submit a written report on the occurrences of faults, malfunctions, defects or other occurrences that cause or might cause adverse effects on the continuing airworthiness of the aircraft, within 72 hours of the occurrence, to the *Chief Executive* and to the following persons:

- a) the aircraft type certificate holder; or
- b) in the case where information on faults, malfunctions, defects and other occurrences relates to an engine or propeller, the aircraft type certificate holder and the organisation responsible for the engine or propeller design; or
- c) in the case of an occurrence associated with a modification, the organisation responsible for the design of the modification

6.4 Modifications and repairs

6.4.1 All modifications and *repairs* shall comply with the requirements contained in the Singapore Airworthiness Requirements (SAR).

6.5 Maintenance release

6.5.1 A *maintenance release* shall be completed and signed to certify that the *maintenance* work performed has been completed satisfactorily and in accordance with data and procedures acceptable to the *Chief Executive*.

6.5.2 A *maintenance release* shall contain a certification including:

- a) basic details of the *maintenance* performed;
- b) the date such *maintenance* was completed;
- c) the identity of the approved *maintenance* organisation; and
- d) the identity of the authorised person or persons signing the release.

7 HELICOPTER FLIGHT CREW

7.1 Qualifications

7.1.1 The *pilot-in-command* of a *Singapore helicopter* shall

- a) ensure that the licences of each *flight crew member* have been issued by the *Chief Executive*;
- b) ensures that the licences of each *flight crew member* are properly rated and of current validity, and
- c) be satisfied that *flight crew members* have maintained competence.

7.1.2 The *pilot-in-command* of a *helicopter* equipped with an airborne collision avoidance system (ACAS) shall ensure that each *flight crew member* has been appropriately trained to competency in the use of ACAS equipment and the avoidance of collision.

7.2 Composition of the *flight crew*

7.2.1 The number and composition of the *flight crew* shall not be less than that specified in the *flight manual* or other documents associated with the certificate of airworthiness.

8 MANUALS, LOGS AND RECORDS

8.1 *Flight manual*

8.1.1 The *helicopter flight manual* shall be updated by implementing changes made mandatory by the *aircraft* manufacturer and/or by the *Chief Executive*.

8.2 Journey log / *Technical log book*

8.2.1 A journey log / technical log book shall be maintained for every *helicopter* engaged in *general aviation* in which shall be entered particulars of the *helicopter*, its crew and each journey.

8.2.2 The *helicopter* journey / technical log should contain the following items:

- a) *helicopter* nationality and registration;
- b) date;
- c) *crew member* names and duty assignments;
- d) departure and arrival *points* and times;
- e) purpose of flight;
- f) observations regarding the flight; and
- g) signature of the *pilot-in-command*.

8.3 Records of *emergency* and survival equipment carried

8.3.1 The owner of the *helicopter*, or in the case where it is leased, the lessee, shall at all times have available for immediate communication to rescue coordination centre, lists containing information on the *emergency* and survival equipment carried on board the *helicopter*. The information shall include, as applicable, the number, colour and type of life rafts and pyrotechnics, details of *emergency* medical supplies, water supplies and the type and frequencies of the *emergency* portable radio equipment.

9 SECURITY

9.1 Security of aircraft

9.1.1 The *pilot-in-command* of a *Singapore helicopter* shall be responsible for the security of the *aircraft* during its operation.

9.2 Reporting acts of unlawful interference

9.2.1 Following an act of unlawful interference, the *pilot-in-command* shall submit a report of such an act to the *Chief Executive* as soon as reasonably practicable.

APPENDIX A

HELICOPTER PERFORMANCE AND OPERATING LIMITATIONS

EFFECTIVE DATE : 30 JULY 2010

REVISION NO : 0 (ISSUE 1)

Purpose and scope

This appendix comprises material that is provided for the purpose of guidance for establishing a *helicopter's* code of performance.

Definitions

Category A With respect to *helicopters*, means a multi-engined *helicopter* designed with engine and system isolation features and capable of operations using take-off and landing data scheduled under a critical engine failure concept which assures adequate designated surface area and adequate performance capability for continued safe flight or safe rejected take-off.

Category B With respect to *helicopters*, means a single engine or multi-engined *helicopter* which does not meet Category A standards. Category B *helicopters* have no guaranteed capability to continue safe flight in the event of an engine failure, and a forced landing is assumed.

Example

Purpose and Scope

The following example provides *quantitative specifications* to illustrate a level of performance intended by the provisions of SGAR- *Helicopters*. Readers may read this as an example of how the *Helicopter's* code of performance may be established.

Abbreviations Specific to *Helicopter* Operations

Abbreviations

| | |
|-------|-----------------------------------------------------------|
| D | Maximum dimension of <i>helicopter</i> |
| DPBL | Defined point before landing |
| DPATO | Defined point after take-off |
| DR | Distance travelled (<i>helicopter</i>) |
| FATO | Final approach and take-off area |
| HFM | <i>Helicopter flight manual</i> |
| LDP | Landing decision point |
| LDAH | Landing distance available (<i>helicopter</i>) |
| LDRH | Landing distance required (<i>helicopter</i>) |
| R | Rotor radius of <i>helicopter</i> |
| RTODR | Rejected take-off distance required (<i>helicopter</i>) |
| TDP | Take-off decision point |
| TLOF | Touchdown and lift-off area |
| TODAH | Take-off distance available (<i>helicopter</i>) |
| TODRH | Take-off distance required (<i>helicopter</i>) |
| VTOSS | Take-off safety speed |

1 DEFINITIONS

1.1 Only applicable to operations in Performance Class 1

Landing distance required (LDRH). The horizontal distance required to land and come to a full stop from a point 15 m (50 ft) above the landing surface.

Rejected take-off distance required (RTODR). The horizontal distance required from the start of the take-off to the point where the *helicopter* comes to a full stop following a power-unit failure and rejection of the take-off at the take-off decision point.

Take-off distance required (TODRH). The horizontal distance required from the start of the take-off to the point at which *VTOSS*, a selected height and a positive climb gradient are achieved, following failure of the critical power-unit being recognised at *TDP*, the remaining power-units operating within approved operating limits.

Note - The selected height stated above is to be determined with reference to either:

- a) *the take-off surface; or*
- b) *a level defined by the highest obstacle in the take-off distance required.*

1.2 Applicable to operations in all performance classes

D. The maximum dimension of the *helicopter*.

Distance DR. DR is the horizontal distance that the *helicopter* has travelled from the end of the take-off distance available.

Landing distance available (LDAH). The length of the *final approach and take-off area* plus any additional area declared available and suitable for *helicopters* to complete the landing manoeuvre from a defined height.

R. The rotor radius of the *helicopter*.

Take-off distance available (TODAH). The length of the *final approach and take-off area* plus the length of *helicopter* clearway (if provided) declared available and suitable for *helicopters* to complete the take-off.

Take-off flight path. The vertical and horizontal path, with the critical power-unit inoperative, from a specified point in the take-off to 300 m (1 000 ft) above the surface.

Touchdown and lift-off area (TLOF). A load bearing area on which a *helicopter* may touch down or lift off.

VTOSS. Take-off safety speed for *helicopters* certificated in Category A.

Vy . Best rate of climb speed.

2 GENERAL

2.1 Reserved

2.2 Significant performance factors

2.2.1 To determine the performance of the *helicopter*, account should be taken of at least the following factors:

- a) Mass of the *helicopter*;
- b) Elevation or pressure-altitude and temperature; and
- c) Wind; for take-off and landing, accountability for wind should be no more than 50 per cent of any reported steady headwind component of 5 knots or more. Where take-off and landing with a tailwind component is permitted in the *flight manual*, not less than 150 per cent of any reported tailwind component should be allowed. Where precise wind measuring equipment enables accurate measurement of wind velocity over the point of take-off and landing, these values may be varied.

2.3 Operating conditions

2.3.1 For *helicopters* operating in *performance Class 2 or 3* in any flight phase where a power-unit failure may cause the *helicopter* to force-land:

- a) A minimum visibility should be defined by the *operator*, taking into account the characteristics of the *helicopter*, but should not be less than 800 m for *helicopters* operating in *performance Class 3*; and
- b) The *operator* should verify that the surface below the intended flight path permits the pilot to execute a *safe forced landing*.

2.4 Obstacle accountability area

2.4.1 For the purpose of the obstacle clearance requirements in 4 below, an obstacle should be considered if its lateral distance from the nearest point on the surface below the intended flight path is not further than:

- a) For VFR operations:
 - 1) half of the minimum width of the *FATO* (or the equivalent term used in the *helicopter flight manual*) defined in the *helicopter flight manual* (or when no width is defined, 0.75 D), plus 0.25 times D (or 3 m, whichever is greater), plus:
 - 0.10 DR for VFR day operations
 - 0.15 DR for VFR *night* operations
- b) for IFR operations:
 - 1) 1.5 D (or 30 m, whichever is greater), plus:
 - 0.10 DR for IFR operations with accurate course guidance
 - 0.15 DR for IFR operations with standard course guidance
 - 0.30 DR for IFR operations without course guidance
- c) for operations with initial take-off conducted visually and converted to IFR/*IMC* at a transition point, the criteria required in 2.4.1 a) apply up to the transition point then the criteria required in 2.4.1 b) apply after the transition point.

- 2.4.2 For a take-off using a backup take-off procedure (or with lateral transition), for the purpose of the obstacle clearance requirements in 4 below, an obstacle located below the backup flight path (lateral flight path) should be considered if its lateral distance from the nearest point on the surface below the intended flight path is not further than half of the minimum width of the *FATO* (or the equivalent term used in the *helicopter flight manual*) defined in the *helicopter flight manual* (when no width is defined, 0.75 D plus 0.25 times D, or 3 m, whichever is greater) plus:
- a) 0.10 distance travelled from the back edge of the *FATO* for VFR day operations;
 - b) 0.15 distance travelled from the back edge of the *FATO* for VFR *night* operations.
- 2.4.3 Obstacles may be disregarded if they are situated beyond:
- a) 7 R for day operations if it is assured that navigational accuracy can be achieved by reference to suitable visual cues during the climb;
 - b) 10 R for *night* operations if it is assured that navigational accuracy can be achieved by reference to suitable visual cues during the climb;
 - c) 300 m if navigational accuracy can be achieved by appropriate navigation aids; and
 - d) 900 m in the other cases.

Note - Standard course guidance includes ADF and VOR guidance. Accurate course guidance includes ILS, MLS, or other course guidance providing an equivalent navigational accuracy.

- 2.4.4 The transition point should not be located before the end of TODRH for *helicopters* operating in *performance Class 1* and before the *DPATO* for *helicopters* operating in *performance Class 2*.
- 2.4.5 When considering the missed approach flight path, the divergence of the obstacle accountability area should only apply after the end of the take-off distance available.

2.5 Source of performance data

- 2.5.1 An *operator* should ensure that the approved performance data contained in the *helicopter flight manual* is used to determine compliance with this Example, supplemented as necessary with other data acceptable to the *State of the Operator*.

3 OPERATING AREA CONSIDERATIONS

3.1 Final approach and take-off area (FATO)

- 3.1.1 For *operations in performance Class 1*, the dimensions of the *FATO* should be at least equal to the dimensions specified in the *helicopter flight manual*.

Note - A FATO that is smaller than the dimensions specified in the helicopter flight manual may be accepted if the helicopter is capable of a hover out of ground effect with one engine inoperative (HOGE OEI), and the conditions of 4.1 below can be met.

4 LIMITATIONS RESULTING FROM PERFORMANCE

4.1 Operations in performance Class 1

4.1.1 Take-off

4.1.1.1 The *take-off* mass of the *helicopter* should not exceed the maximum *take-off* mass specified in the *flight manual* for the procedure to be used and to achieve a rate of climb of 100 ft/min at 60 m (200 ft) and 150 ft/min at 300 m (1 000 ft) above the level of the *heliport* with the critical engine inoperative and the remaining power-units operating at an appropriate power rating, taking into account the parameters specified in 2.2 (Figure A-1).

4.1.1.2 Rejected take-off

The *take-off* mass should be such that the rejected *take-off* distance required does not exceed the rejected *take-off* distance available.

4.1.1.3 Take-off distance

The *take-off* mass should be such that the *take-off* distance required does not exceed the *take-off* distance available.

Note 1 - As an alternative, the requirement above may be disregarded provided that the helicopter with the critical power-unit failure recognised at TDP can, when continuing the take-off, clear all obstacles from the end of the take-off distance available to the end of the take-off distance required by a vertical margin of not less than 10.7 m (35 ft) (Figure A-2).

Note 2 - For elevated heliports, the airworthiness code provides appropriate clearance from the elevated heliport edge (Figure A-3).

4.1.1.4 Backup procedures (or procedures with lateral transition)

An *operator* should ensure that, with the critical power-unit inoperative, all obstacles below the backup flight path (the lateral flight path) are cleared by an adequate margin. Only the obstacles specified in 2.4.2 should be considered.

4.1.2 Take-off flight path

From the end of the *take-off* distance required with the critical power-unit inoperative:

4.1.2.1 The *take-off* mass should be such that the climb path provides a vertical clearance of not less than 10.7 m (35 ft) for VFR operations and 10.7 m (35 ft) plus 0.01 DR for IFR operations above all obstacles located in the climb path. Only obstacles as specified in 2.4 should be considered.

4.1.2.2 Where a change of direction of more than 15 degrees is made, obstacle clearance requirements should be increased by 5 m (15 ft) from the point at which the turn is initiated. This turn should not be initiated before reaching a height of 60 m (200 ft) above the *take-off* surface, unless permitted as part of an approved procedure in the *flight manual*.

4.1.3 *En route*

The *take-off* mass is such that it is possible, in case of the critical power-unit failure occurring at any point of the flight path, to continue the flight to an appropriate landing site and achieve the minimum flight altitudes for the route to be flown.

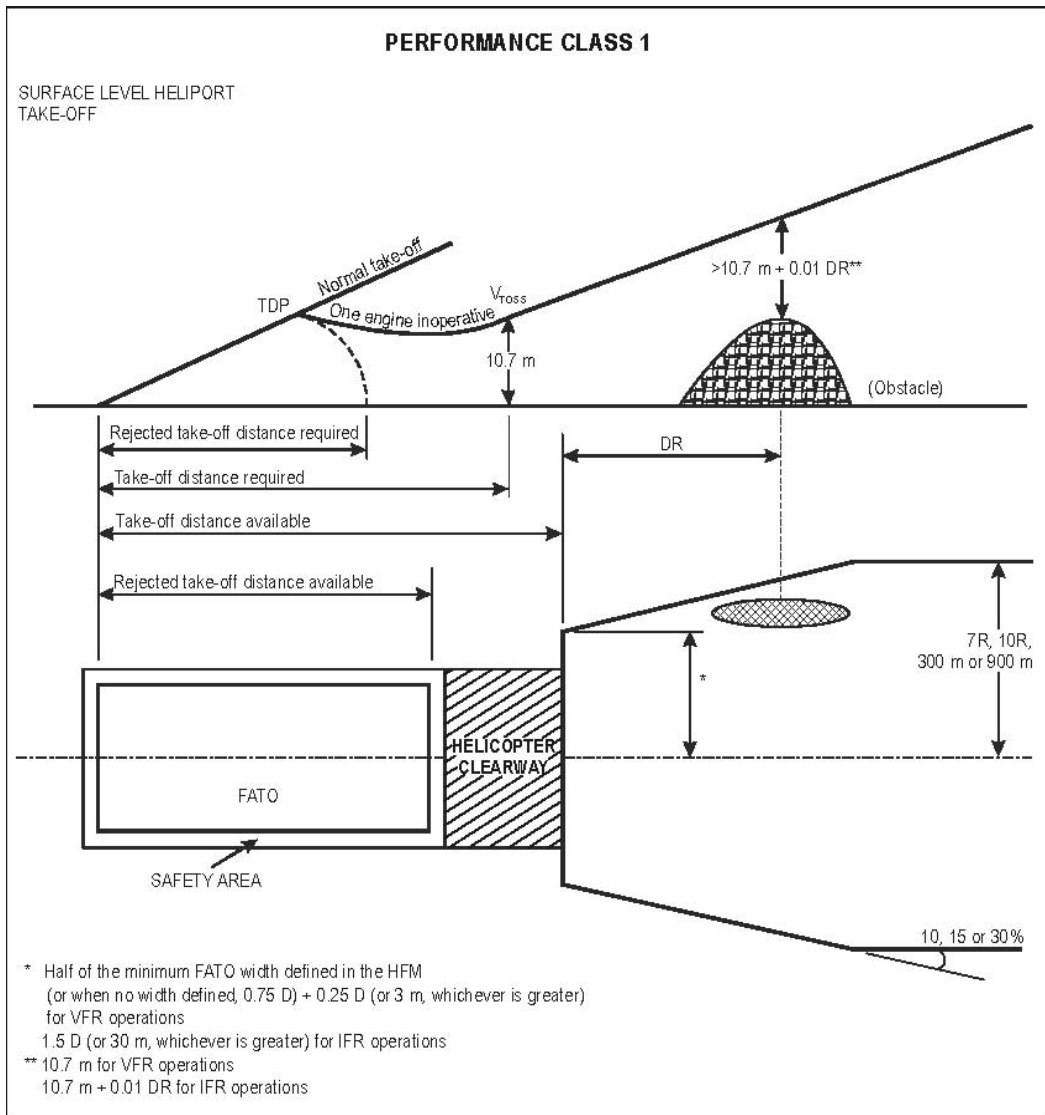

Figure A-1

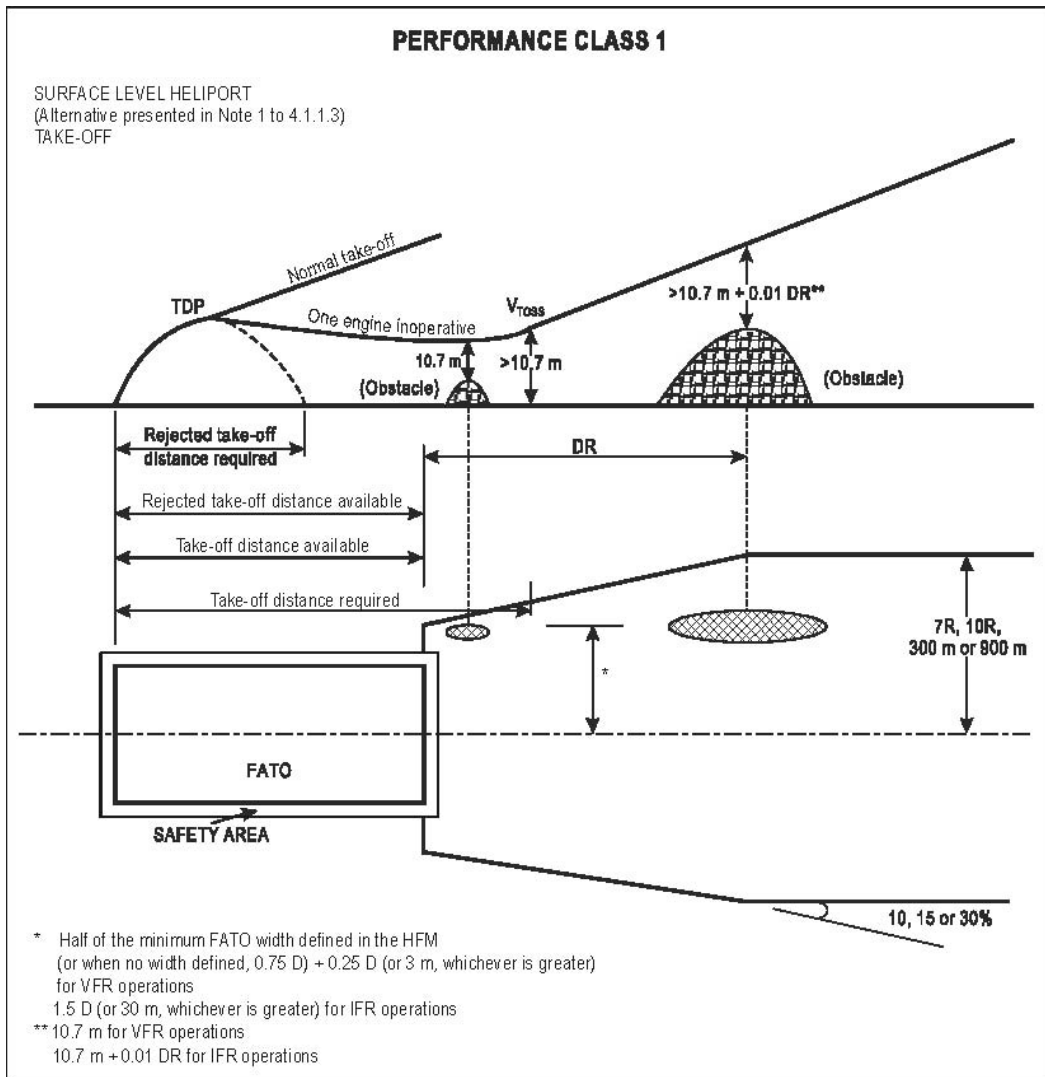

Figure A-2

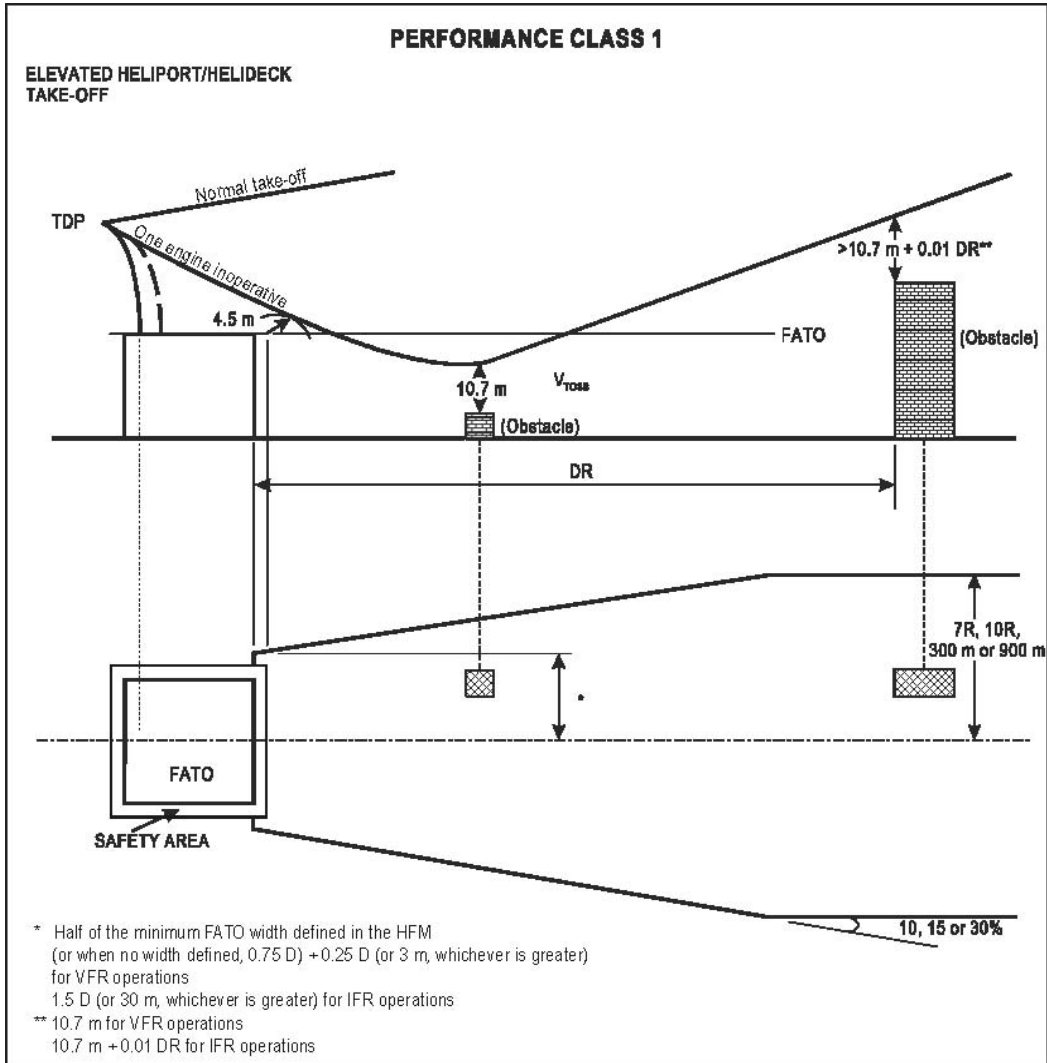

Figure A-3

4.1.4 Approach, landing and balked landing (Figures A-4 and A-5)

The estimated landing mass at the destination or alternate should be such that:

- a) it does not exceed the maximum landing mass specified in the *flight manual* for the procedure to be used and to achieve a rate of climb of 100 ft/min at 60 m (200 ft) and 150 ft/min at 300 m (1 000 ft) above the level of the *heliport* with the critical engine inoperative and the remaining power-units operating at an appropriate power rating, taking into account the parameters specified in 2.2;
- b) the landing distance required does not exceed the landing distance available unless the *helicopter*, with the critical power-unit failure recognised at *LDP* can, when landing, clear all obstacles in the approach path;
- c) in case of the critical power-unit failure occurring at any point after the *LDP*, it is possible to land and stop within the *FATO*; and
- d) in the event of the critical power-unit failure being recognised at the *LDP* or at any point before the *LDP*, it is possible either to land and stop within the *FATO* or to overshoot, meeting the conditions of 4.1.2.1 and 4.1.2.2.

Note - For elevated heliports, the airworthiness code provides appropriate clearance from the elevated heliport edge.

4.2 **Operations in performance Class 2**

4.2.1 Take-off (Figures A-6 and A-7)

The mass of the *helicopter* at *take-off* should not exceed the maximum *take-off* mass specified in the *flight manual* for the procedures to be used and to achieve a rate of climb of 150 ft/min at 300 m (1 000 ft) above the level of the *heliport* with the critical power-unit inoperative and the remaining power-units operating at an appropriate power rating, taking into account the parameters specified in 2.2.

4.2.2 Take-off flight path

From *DPATO* or, as an alternative, no later than 60 m (200 ft) above the *take-off* surface with the critical power-unit inoperative, the conditions of 4.1.2.1 and 4.1.2.2 should be met.

4.2.3 En route

The requirements of 4.1.3 should be met.

4.2.4 Approach, landing and balked landing (Figures A-8 and A-9)

The estimated landing mass at the destination or alternate should be such that:

- a) it does not exceed the maximum landing mass specified in the *flight manual* for a rate of climb of 150 ft/min at 300 m (1 000 ft) above the level of the *heliport* with the critical power-unit inoperative and the remaining power units operating at an appropriate power rating, taking into account the parameters specified in 2.2;

- b) it is possible, in case of the critical power-unit failure occurring at or before the *DPBL*, either to perform a *safe forced landing* or to overshoot, meeting the requirements of 4.1.2.1 and 4.1.2.2.

Only obstacles as specified in 2.4 should be considered.

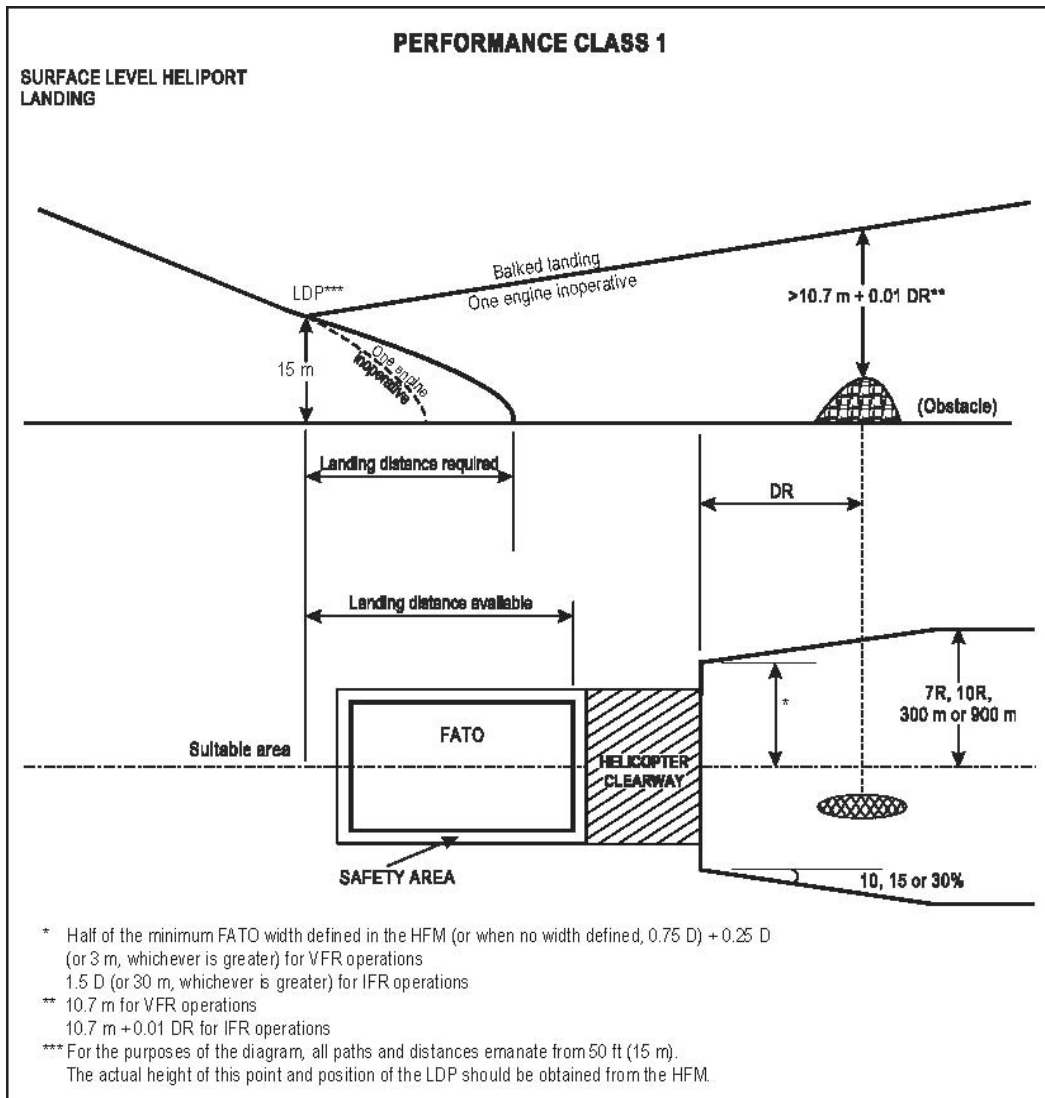

Figure A-4

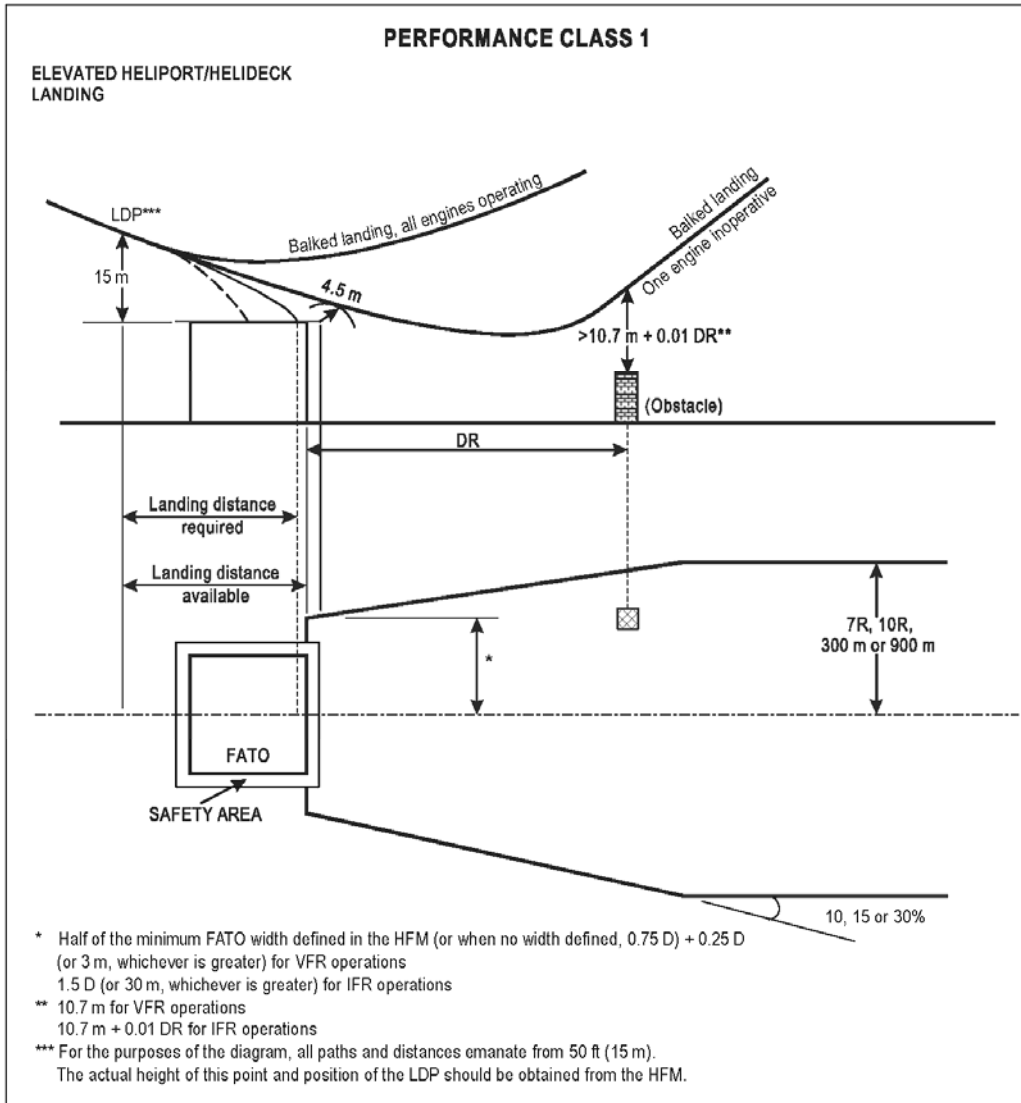

Figure A-5

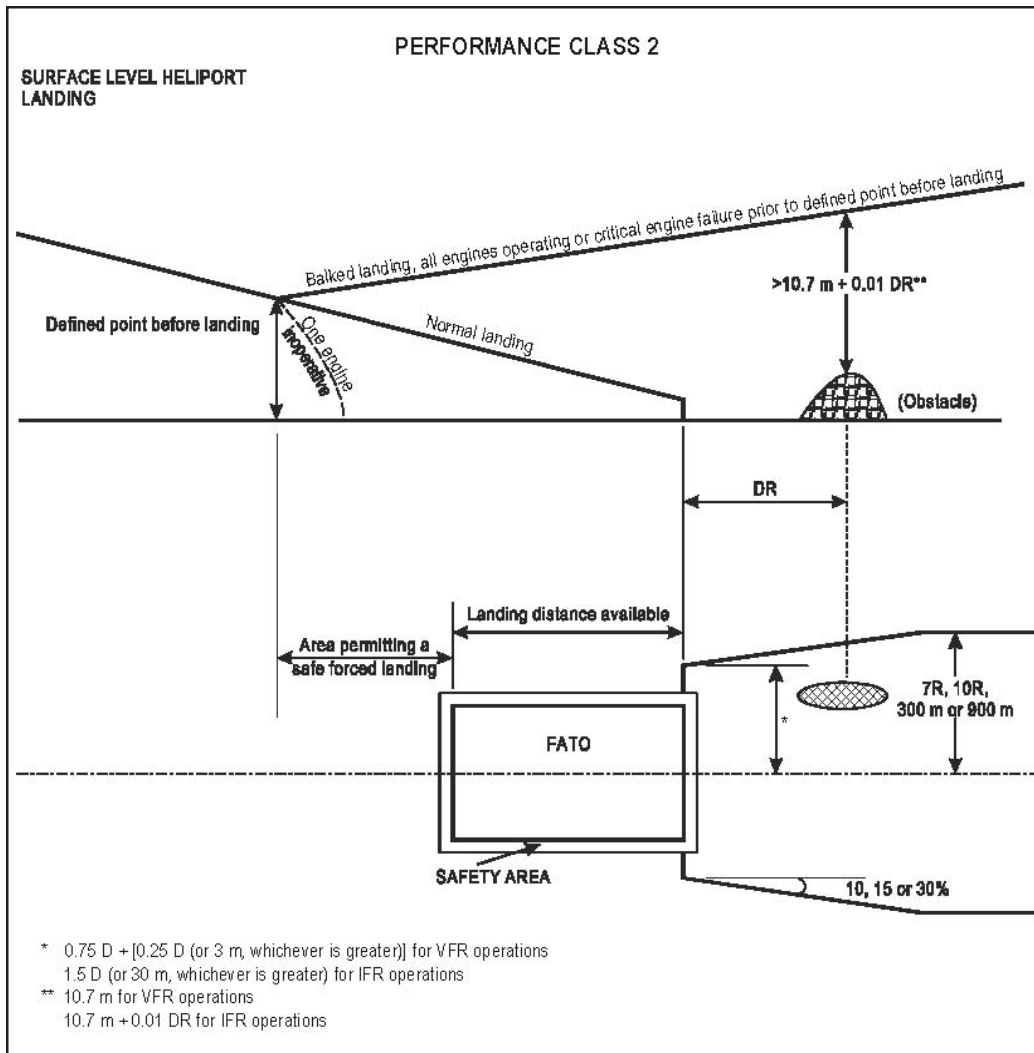

Figure A-8

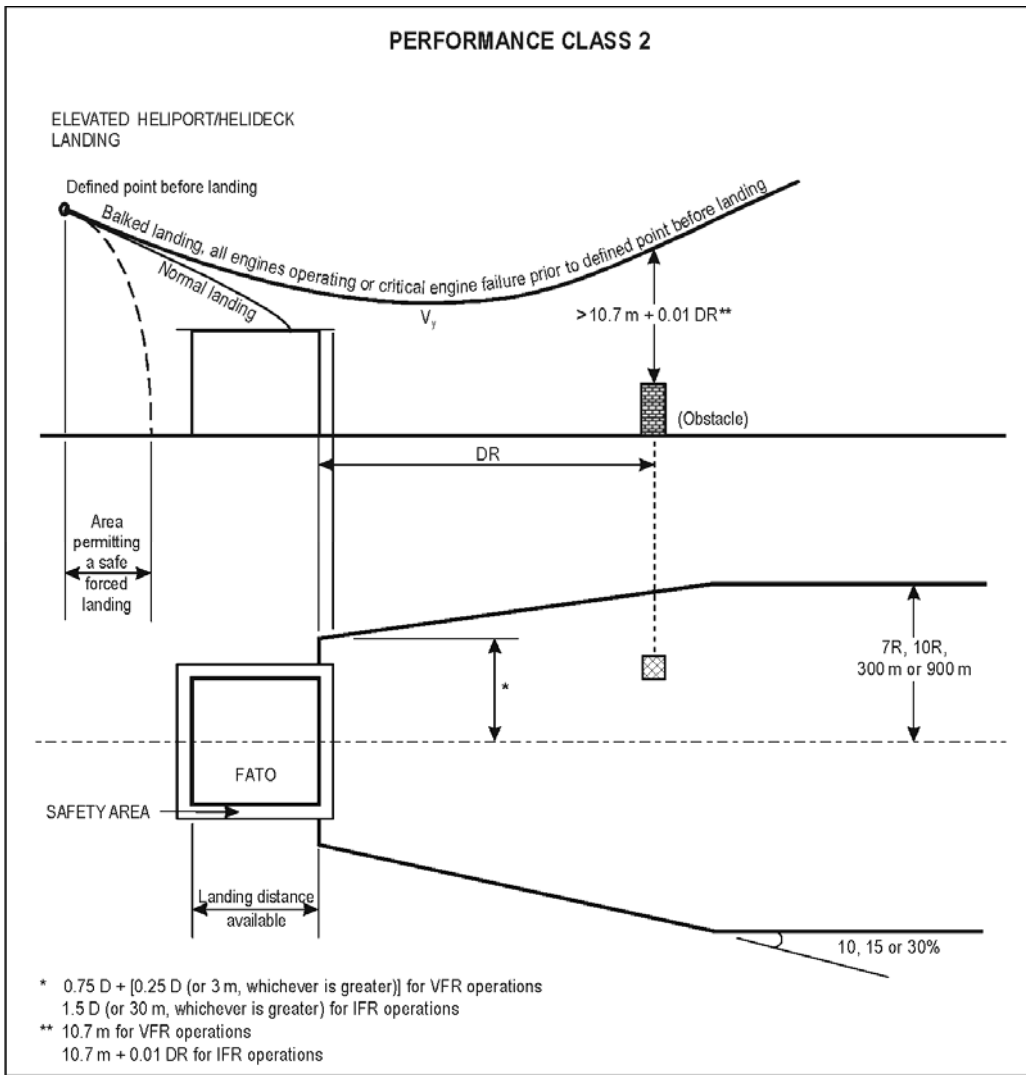

Figure A-9

4.3 ***Operations in performance Class 3***

4.3.1 ***Take-off***

The mass of the *helicopter* at *take-off* should not exceed the maximum *take-off* mass specified in the *flight manual* for a hover in ground effect with all power-units operating at *take-off* power, taking into account the parameters specified in 2.2. If conditions are such that a hover in ground effect is not likely to be established, the *take-off* mass should not exceed the *maximum mass* specified for a hover out of ground effect with all power-units operating at *take-off* power, taking into account the parameters specified in 2.2.

4.3.2 ***Initial climb***

The *take-off* mass should be such that the climb path provides adequate vertical clearance above all obstacles located along the climb path, all engines operating.

4.3.3 ***En route***

The *take-off* mass is such that it is possible to achieve the minimum flight altitudes for the route to be flown, all engines operating.

4.3.4 ***Approach and landing***

The estimated landing mass at the destination or alternate should be such that:

- a) It does not exceed the maximum landing mass specified in the *flight manual* for a hover in ground effect with all power-units operating at *take-off* power, taking into account the parameters specified in 2.2. If conditions are such that a hover in ground effect is not likely to be established, the *take-off* mass should not exceed the *maximum mass* specified for a hover out of ground effect with all power-units operating at *take-off* power, taking into account the parameters specified in 2.2;
- b) It is possible to perform a balked landing, all engines operating, at any point of the flight path and clear all obstacles by an adequate vertical interval.

APPENDIX B

CARRIAGE AND USE OF OXYGEN

EFFECTIVE DATE : 30 JULY 2010
REVISION NO : 0 (ISSUE 1)

1 OXYGEN SUPPLY

- 1.1 A flight to be operated at altitudes at which the atmospheric pressure in personnel compartments will be less than 700 hPa should not be commenced unless sufficient stored breathing oxygen is carried to supply:
- a) all *crew members* and at least 10 per cent of the passengers for any period in excess of 30 minutes that the pressure in compartments occupied by them will be between 700 hPa and 620 hPa; and
 - b) all *crew members* and passengers for any period that the atmospheric pressure in compartments occupied by them will be less than 620 hPa.
- 1.2 A flight to be operated with a pressurised *aircraft* should not be commenced unless a sufficient quantity of stored breathing oxygen is carried to supply all *crew members* and passengers, as is appropriate to the circumstances of the flight being undertaken, in the event of loss of pressurisation, for any period that the atmospheric pressure in any compartment occupied by them would be less than 700 hpa. In addition, when an *aircraft* is operated at flight altitudes at which the atmospheric pressure is less than 376 hPa, or which, if operated at flight altitudes at which the atmospheric pressure is more than 376 hPa and cannot descend safely within four minutes to a flight altitude at which the atmospheric pressure is equal to 620 hPa, there shall be no less than a 10-minute supply for the occupants of the passenger compartment.

2 USE OF OXYGEN

- 2.1 All *flight crew* members, when engaged in performing duties essential to the safe operation of a *helicopter* in flight, should use breathing oxygen continuously whenever the circumstances prevail for which its supply has been indicated to be necessary in 1.1 or 1.2.

- 2.2 All *flight crew* members of pressurised *aircraft* operating above an altitude where the atmospheric pressure is less than 376 hPa should have available at the flight duty station a quick donning type of mask which will readily supply oxygen upon demand.

Note - Approximate altitudes in the Standard Atmosphere corresponding to the values of absolute pressure used in the text are as follows:

| Absolute pressure | Metres | Feet |
|--------------------------|---------------|---------------|
| <i>700 hPa</i> | <i>3 000</i> | <i>10 000</i> |
| <i>620 hPa</i> | <i>4 000</i> | <i>13 000</i> |
| <i>376 hPa</i> | <i>7 600</i> | <i>25 000</i> |

APPENDIX C

OPERATIONS MANUAL

EFFECTIVE DATE : 30 JULY 2010
REVISION NO : 0 (ISSUE 1)

The following is the suggested content of an *operations manual*. It may be issued in separate parts corresponding to specific aspects of an operation. It should include the instructions and information necessary to enable the personnel concerned to perform their duties safely and shall contain at least the following information:

- a) table of contents;
- b) amendment control page and list of effective pages, unless the entire document is reissued with each amendment and the document has an effective date on it;
- c) duties, responsibilities and succession of management and operating personnel;
- d) *operator safety management system*;
- e) *operational control system*;
- f) *MEL* procedures (where applicable);
- g) normal flight operations;
- h) SOPs;
- i) weather limitations;
- j) flight and duty time limitations;
- k) emergency operations;
- l) accident/incident considerations;
- m) personnel qualification and training;
- n) record keeping;
- o) a description of the *maintenance control system*;
- p) security procedures (where applicable);
- q) performance operating limitations;
- r) use/protection of FDR/CVR records (where applicable); and
- s) handling of *dangerous goods*.

Intentionally Left Blank

APPENDIX D

MINIMUM EQUIPMENT LIST (MEL)

EFFECTIVE DATE : 30 JULY 2010
REVISION NO : 0 (ISSUE 1)

- 1 If deviations from the requirements in the certification of *aircraft* were not permitted, an *aircraft* could not be flown unless all systems and equipment were operable. Experience has proved that some unserviceability can be accepted in the short term when the remaining operative systems and equipment provide for continued safe operations.
- 2 To permit an *aircraft* to fly with certain acceptable component unserviceability, a *minimum equipment list*, approved by the *Chief Executive*, is therefore necessary for each *aircraft*, based on the *master minimum equipment list* established for the *aircraft* type by the organisation responsible for the type design in conjunction with the State of Design.
- 4 The *operator* is required to prepare a *minimum equipment list* designed to allow the operation of an *aircraft* with certain systems or equipment inoperative provided an acceptable level of safety is maintained.
- 5 The *minimum equipment list* is not intended to provide for operation of the *aircraft* for an indefinite period with inoperative systems or equipment. The basic purpose of the *minimum equipment list* is to permit the safe operation of an *aircraft* with inoperative systems or equipment within the framework of a controlled and sound programme of *repairs* and parts replacement.
- 6 *Operators* are to ensure that no flight is commenced with multiple *minimum equipment list* items inoperative without determining that any interrelationship between inoperative systems or components will not result in an unacceptable degradation in the level of safety and/or undue increase in the *flight crew* workload.
- 7 The exposure to additional failures during continued operation with inoperative systems or equipment should also be considered in determining that an acceptable level of safety is being maintained. The *minimum equipment list* may not deviate from requirements of the *flight manual* limitations section, emergency procedures or other airworthiness requirements of the *Chief Executive*.
- 8 Systems or equipment accepted as inoperative for a flight should be placarded where appropriate and all such items should be noted in the *aircraft* technical log to inform the *flight crew* and *maintenance* personnel of the inoperative system or equipment.
- 9 For a particular system or item of equipment to be accepted as inoperative, it may be necessary to establish a *maintenance* procedure, for completion prior to flight, to deactivate or isolate the system or equipment. It may similarly be necessary to prepare an appropriate *flight crew* operating procedure.
- 10 The responsibilities of the *pilot-in-command* in accepting an *aircraft* for operation with deficiencies in accordance with a *minimum equipment list* are specified in 2.2.3.1.

11 Guidelines on the preparation of the *MEL* can be found in SAR Chapter 4.10.